

Data Projector

Operating Instructions

VPL-CX100
VPL-CX120/CX125
VPL-CX150/CX155
VPL-CW125

WARNING

To reduce the risk of fire or electric shock, do not expose this apparatus to rain or moisture.

To avoid electrical shock, do not open the cabinet. Refer servicing to qualified personnel only.

WARNING

THIS APPARATUS MUST BE EARTHED.

WARNING

When installing the unit, incorporate a readily accessible disconnect device in the fixed wiring, or connect the power plug to socket-outlet which must be provided near the unit and easily accessible.

If a fault should occur during operation of the unit, operate the disconnect device to switch the power supply off, or disconnect the power plug.

WARNING: THIS WARNING IS APPLICABLE FOR USA ONLY.

If used in USA, use the UL LISTED power cord specified below.

DO NOT USE ANY OTHER POWER CORD.

Plug Cap	Parallel blade with ground pin (NEMA 5-15P Configuration)
Cord	Type SJT, three 16 or 18 AWG wires
Length	Minimum 1.5 m (4 ft .11in.), Less than 2.5 m (8 ft .3 in.)
Rating	Minimum 10 A, 125 V

Using this unit at a voltage other than 120V may require the use of a different line cord or attachment plug, or both.

To reduce the risk of fire or electric shock, refer servicing to qualified service personnel.

WARNING: THIS WARNING IS APPLICABLE FOR OTHER COUNTRIES.

1 Use the approved Power Cord (3-core mains lead) / Appliance Connector / Plug with earthing-contacts that conforms to the safety regulations of each country if applicable.

2 Use the Power Cord (3-core mains lead) / Appliance Connector / Plug conforming to the proper ratings (Voltage, Ampere).

If you have questions on the use of the above Power Cord / Appliance Connector / Plug, please consult a qualified service personnel.

IMPORTANT

The nameplate is located on the bottom.

CAUTION

Danger of explosion if battery is incorrectly replaced.

Replace only with the same or equivalent type recommended by the manufacturer. Dispose of used batteries according to the manufacturer's instructions.

For the customers in the U.S.A

This equipment has been tested and found to comply with the limits for a Class B digital device, pursuant to Part 15 of the FCC Rules. These limits are designed to provide reasonable protection against harmful interference in a residential installation. This equipment generates, uses, and can radiate radio frequency energy and, if not installed and used in accordance with the instructions, may cause harmful interference to radio communications. However, there is no guarantee that interference will not occur in a particular installation. If this equipment does cause harmful interference to radio or television reception, which can be determined by turning the equipment off and on, the user is encouraged to try to correct the interference by one or more of the following measures:

- Reorient or relocate the receiving antenna.
- Increase the separation between the equipment and receiver.
- Connect the equipment into an outlet on a circuit different from that to which the receiver is connected.
- Consult the dealer or an experienced radio/TV technician for help.

You are cautioned that any changes or modifications not expressly approved in this manual could void your authority to operate this equipment.

All interface cables used to connect peripherals must be shielded in order to comply with the limits for a digital device pursuant to Subpart B of Part 15 of FCC Rules.

This device complies with Part 15 of the FCC Rules. Operation is subject to the following two conditions: (1) this device may not cause harmful interference, and (2) this device must accept any interference received, including interference that may cause undesired operation.

If you have any questions about this product, you may call;

*Sony Customer Information Service Center
1-800-222-7669 or <http://www.sony.com/>*

Declaration of Conformity

Trade Name: SONY
Model: VPL-CX100, VPL-CX120,
VPL-CX125, VPL-CX150,
VPL-CX155, VPL-CW125
Responsible party:
Sony Electronics Inc.
Address: 16530 Via Esprillo, San
Diego, CA 92127U.S.A.
Telephone Number:
858-942-2230

This device complies with part 15 of the FCC Rules. Operation is subject to the following two conditions: (1) this device may not cause harmful interference, and (2) this device must accept any interference received, including interference that may cause undesired operation.

For the customers in Canada

This Class B digital apparatus complies with Canadian ICES-003.

For the customers in Europe

The manufacturer of this product is Sony Corporation, 1-7-1 Konan, Minato-ku, Tokyo, Japan.
The Authorized Representative for EMC and product safety is Sony Deutschland GmbH, Hedelfinger Strasse 61, 70327 Stuttgart, Germany. For any service or

guarantee matters please refer to the addresses given in separate service or guarantee documents.

For the State of California, USA only

Perchlorate Material - special handling may apply, See

www.dtsc.ca.gov/hazardouswaste/perchlorate

Perchlorate Material: Lithium battery contains perchlorate.

Disposal of the used lamp

For the customers in the USA

Lamp in this product contains mercury. Disposal of these materials may be regulated due to environmental considerations. For disposal or recycling information, please contact your local authorities or the Electronic Industries Alliance (www.eiae.org).

For safety

Be sure to attach the air filter to the unit.

For the customers in Taiwan only



廢電池請回收

Table of Contents

Precautions	6
Notes on Installation and Usage	7
Unsuitable Installation	7
Usage in High Altitude	8
Unsuitable Conditions	9

Overview

About the Supplied Manuals	10
Features	11
Location and Function of Controls	
(Main Unit)	13
Top/Front/Side	13
Rear/Side/Bottom	13
Control Panel	15
Connector Panel	16
Remote Commander	17
VPL-CX125/CX155/CW125	17
VPL-CX100/CX120/CX150	19

Projecting the Picture

Installing the Projector	21
Connecting the Projector	23
Connecting a Computer	23
Connecting a VCR	24
Projecting	26
Turning Off the Power	28

Convenient Functions

Selecting the Menu Language	29
Security Lock	30
Other Functions	32
Direct Power On/Off Function ...	32

Effective Tools for Your	
Presentation	32
Controlling the Computer Using a	
Presentation Tool, RM-PJPK1	
(not supplied) (When Using the	
Network Presentation Function)	
(VPL-CX125/CX155/CW125	
only)	33

Adjustments and Settings Using a Menu

Using a MENU	34
The Picture Menu	36
The Signal Menu	37
About the Preset Memory No.	38
The Function Menu	39
The Installation Menu	41
The Setup Menu	43
The Information Menu	44

Maintenance

Replacing the Lamp	46
Cleaning the Air Filter	48

Others

Troubleshooting	49
Messages List	53
Specifications	54
Installation Diagram	59
Floor Installation (Front	
Projection)	59
Ceiling Installation (Front	
Projection)	61

“Side Shot” (VPL-CX125/CX155/
CW125 only) and “V Keystone”
Adjustments63
Dimensions65
Index68

Precautions

On safety

- Check that the operating voltage of your unit is identical with the voltage of your local power supply. If voltage adaptation is required, consult with qualified Sony personnel.
- Should any liquid or solid object fall into the cabinet, unplug the unit and have it checked by qualified Sony personnel before operating it further.
- Unplug the unit from the wall outlet if it is not to be used for several days.
- To disconnect the cord, pull it out by the plug. Never pull the cord itself.
- The wall outlet should be near the unit and easily accessible.
- The unit is not disconnected from the AC power source (mains) as long as it is connected to the wall outlet, even if the unit itself has been turned off.
- Do not look into the lens while the lamp is on.
- Do not place your hand or objects near the ventilation holes — the air coming out is hot.
- Be careful not to catch your fingers by the adjuster when you adjust the height of the unit. Do not push hard on the top of the unit with the adjuster out.
- Be sure to grasp both sides of the unit with both hands when carrying the unit.

On illumination

- To obtain the best picture, the front of the screen should not be exposed to direct lighting or sunlight.
- Ceiling-mounted spot lighting is recommended. Use a cover over fluorescent lamps to avoid lowering the contrast ratio.
- Cover any windows that face the screen with opaque draperies.
- It is desirable to install the unit in a room where floor and walls are not of light-reflecting material. If the floor and walls are of reflecting material, it is recommended that the carpet and wall paper be changed to a dark color.

On preventing internal heat build-up

The unit is equipped with ventilation holes (intake) at the bottom and ventilation holes (exhaust) at the side. Do not block or place anything near these holes, or internal heat build-up may occur, causing picture degradation or damage to the unit.

On cleaning

Before cleaning

Be sure to disconnect the AC power cord from the AC outlet.

On cleaning the air filter

- Clean the air filter whenever you replace the lamp.
- Refer to the “Cleaning the Air Filter” on page 48 for the air filter cleaning.

On cleaning the lens

The lens surface is especially treated to reduce reflection of light.

As incorrect maintenance may impair the performance of the projector, take care with respect to the following:

- Avoid touching the lens. To remove dust on the lens, use a soft dry cloth. Do not use a damp cloth, detergent solution, or thinner.
- Wipe the lens gently with a soft cloth such as a cleaning cloth or glass cleaning cloth.
- Stubborn stains may be removed with a soft cloth such as a cleaning cloth or glass cleaning cloth lightly dampened with water.
- Never use solvent such as alcohol, benzene or thinner, or acid, alkaline or abrasive detergent, or chemical cleaning cloth, as they will damage the lens surface.

On cleaning the cabinet

- Clean the cabinet gently with a soft dry cloth. Stubborn stains may be removed with a cloth lightly dampened with mild detergent solution, followed by wiping with a soft dry cloth.
- Use of alcohol, benzene, thinner or insecticide may damage the finish of the cabinet or remove the indications on the cabinet. Do not use these chemicals.

- If you rub on the cabinet with a stained cloth, the cabinet may be scratched.
- If the cabinet is in contact with a rubber or vinyl resin product for a long period of time, the finish of the cabinet may deteriorate or the coating may come off.

On LCD projector

- The LCD projector is manufactured using high-precision technology. You may, however, see tiny black points and/or bright points (red, blue, or green) that continuously appear on the LCD projector. This is a normal result of the manufacturing process and does not indicate a malfunction.

Notes on Installation and Usage

Unsuitable Installation

Do not install the unit in the following situations. **These installations may cause malfunction or damage** to the unit.

Poorly ventilated

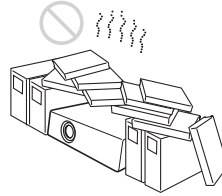

- Allow adequate air circulation to prevent internal heat build-up. Do not place the unit on surfaces (rugs, blankets, etc.) or near materials (curtains, draperies) that may block the ventilation holes.
- When the internal heat builds up due to the block-up, the temperature sensor will function with the message “High temp.! Lamp off in 1 min.” The power will be turned off automatically after one minute.
- Leave space of more than 30 cm (11 ⁷/₈ inches) around the unit.
- Be careful that the ventilation holes may inhale tininess such as a piece of paper.

Highly heated and humid

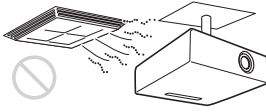

- Avoid installing the unit in a location where the temperature or humidity is very high, or temperature is very low.
- To avoid moisture condensation, do not install the unit in a location where the temperature may rise rapidly.

Subject to direct cool or warm air from an air-conditioner

Installing in such a location may cause malfunction of the unit due to moisture condensation or rise in temperature.

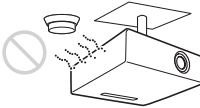
Near a heat or smoke sensor

Malfunction of the sensor may be caused.

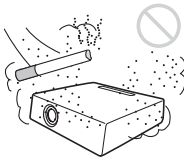
Very dusty, extremely smoky

Avoid installing the unit in a very dusty or extremely smoky environment. Otherwise, the air filter will become obstructed, and this may cause a malfunction of the unit or damage it. Dust preventing the air passing through the filter may cause a rise in the internal temperature of the unit. Clean the air filter whenever you replace the lamp.

Usage in High Altitude

When using the unit at an altitude of 1,500 m or higher, set the “High Altitude Mode” to “On” in the Installation menu. Failing to set this mode when using the unit at high altitudes could have adverse effects, such as reducing the reliability of certain components.

Note on the screen

When using a screen with an uneven surface, stripes pattern may rarely appear on the screen depending on the distance between the screen and the unit or the zooming magnifications. This is not a malfunction of the unit.

Unsuitable Conditions

Do not use the unit under the following conditions.

Do not topple the unit

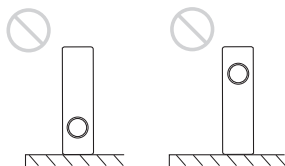

Avoid using as the unit topples over on its side. It may cause malfunction.

Do not tilt right/left

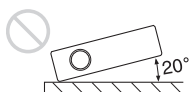

Avoid using as the unit tilts more than 20 degrees. Do not install the unit other than on the floor or ceiling. These installations may cause malfunction.

Do not block the ventilation holes



Avoid using something to cover over the ventilation holes (exhaust/intake); otherwise, the internal heat may build up.

Do not place a blocking object just in front of the lens

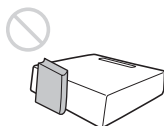

Do not place any object just in front of the lens that may block the light during projection. Heat from the light may damage the object. Use the PIC MUTING key to cut off the picture.

Do not use the Security bar for transporting or installation

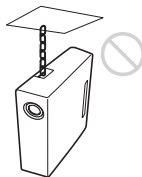

Use the Security bar at the side of the projector for a purpose of preventing theft, by attaching a commercially available theft prevention cable for example. If you lift the projector by holding the Security bar, or hang the projector by using this bar, it may cause the projector to fall or be damaged.

About the Supplied Manuals

The following manuals and softwares are supplied with the projector.
On Macintosh system, you can read only the Operating Instructions.

This manual contains explanations for the VPL-CX100, VPL-CX120, VPL-CX125, VPL-CX150, VPL-CX155 and VPL-CW125 all together. Be aware that the VPL-CX155 is mainly used for explanation of the display, and there may be an item that is not displayed due to the model.

Manuals

Safety Regulations (separately printed manual)

This manual describes important notes and cautions to which you have to pay attention when handling and using this projector.

Quick Reference Manual (separately printed manual)

This manual describes basic operations for projecting pictures after you have made the required connections.

Operating Instructions (on the CD-ROM) (this manual)

This Operating Instructions describes the setup and operations of this projector.

Operating Instructions for Network (on the CD-ROM)

This Operating Instructions describes how to set up and operate the network presentation.

Note

You must have Adobe Acrobat Reader 5.0 or higher is installed to read the Operating Instructions stored on the CD-ROM.

Software (on the CD-ROM)

Projector Station for Air Shot Version 2 (Version 2.xx) (Japanese and English only)

This is an application software for transmitting data from a computer to the projector.

Features

High brightness, high picture quality

High brightness

Adoption of Sony's unique optical system provides a high-efficiency optical system. It allows light output of 3500 lumen for the VPL-CX150/CX155, 3000 lumen for the VPL-CX120/CX125/CW125 and 2700 lumen for the VPL-CX100.

High picture quality

VPL-CX100/CX120/CX125/CX150/CX155

Three super-high-aperture 0.79-inch XGA panels with approximately 790,000 effective pixels produce a resolution of 1024 × 768 dots (horizontal/vertical) for RGB input, and 750 horizontal TV lines for video input.

VPL-CW125

Three super-high-aperture 0.74-inch WXGA panels with approximately 1,090,000 effective pixels produce a resolution of 1366 × 800 dots (horizontal/vertical) for RGB input, and 750 horizontal TV lines for video input.

Versatile installation capability

Capable of floor, ceiling or tilt installation

In addition to the front floor or ceiling installation, you can install the projector by tilting it 90 degrees at the rear or 90 degrees in front.

Direct Power On/Off function

The AC power of the entire system can be directly turned on/off with a breaker or other switch without pressing the power key on the projector.

Simple maintenance

Even when the projector is mounted on the ceiling you can change the lamp or clean the air filter easily because the replacement lamp is located at the rear of the projector and the air filter is located at the front of the

projector. Clean the air filter whenever you replace the lamp.

ID function (VPL-CX125/CX155/CW125 only)

The function allows you to adjust or control each projector individually with one Remote Commander when you use two or more projectors in one room.

System expandability using a network (VPL-CX125/CX155/CW125 only)

Connection to a LAN allows you to turn the projector on/off away from the installation location via a Web browser or to obtain projector status information such as the lamp timer.

Side Shot (VPL-CX125/CX155/CW125 only)

The projector supports the Side Shot feature (horizontal trapezoidal correction function), enabling projection from the side of the screen. Installation becomes possible in a wider variety of locations.

Security Functions

Security lock

This function makes it possible to prevent projection of a picture on the screen unless the required password is entered when the projector is turned on.

Panel key lock

This function locks all the keys on the control panel of the projector, allowing use of the keys on the Remote Commander. This prevents the projector from operating incorrectly.

Network Presentation (VPL-CX125/CX155/CW125 only)

Any image of a computer, if it is connected to a LAN by wired or wireless connection, can be projected by connecting a network cable to the NETWORK connector (RJ-45) of the projector.

For details, refer to the "Operating Instructions for Network."

Other Convenient Functions

- Low fan noise makes your presentation comfortable
- On-screen menu in 15 languages
- Picture/Audio muting
- Freeze
- Lamp mode switching function
- Low power consumption in standby
- Security bar

About Trademarks

- Adobe Acrobat is a trademark of Adobe Systems Incorporated.
- Windows is a registered trademark of Microsoft Corporation in the United States and/or other countries.
- Kensington is a registered trademark of Kensington Technology Group.
- Macintosh is a registered trademark of Apple Computer, Inc.
- VESA is a registered trademark of the Video Electronics Standards Association.
- Display Data Channel is a trademark of the Video Electronics Standards Association.
- Air Shot is a trademark of Sony corporation.
- Side Shot is a trademark of Sony corporation.
- All other trademarks and registered trademarks are trademarks or registered trademarks of their respective holders. In this manual, TM and © marks are not specified.

Location and Function of Controls (Main Unit)

Top/Front/Side

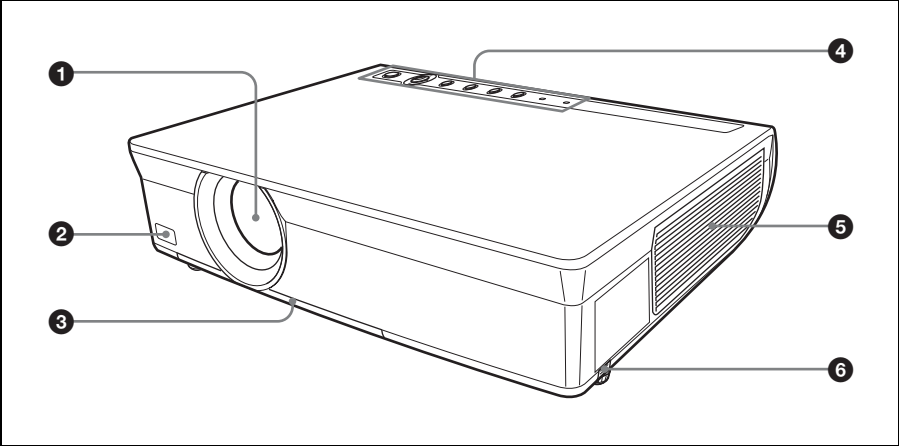

Rear/Side/Bottom

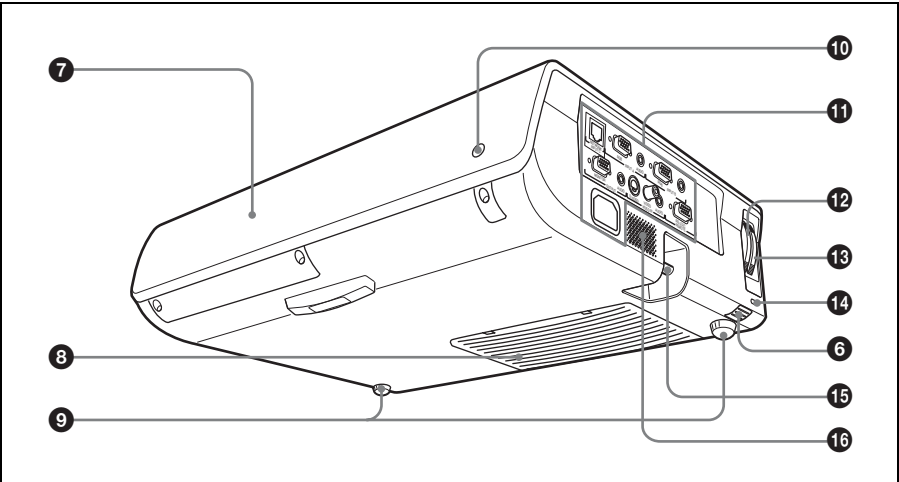

- 1 Lens**
Remove the lens cap before projection.
- 2 Front remote control detector**
- 3 Air filter cover**

Note

To maintain optimal performance, **clean the air filter whenever you replace the lamp.**

For details, see “Cleaning the Air Filter” on page 48.

4 Control panel/Indicator

For details, see “Control Panel” on page 15.

5 Ventilation holes (exhaust)

6 Adjuster adjustment button

For details, see “Using the adjuster” on page 27.

7 Lamp cover

8 Ventilation holes (intake)

9 Adjusters

10 Rear remote control detector

11 Connector/Connector Panel

For details, see “Connector Panel” on page 16.

12 Zoom ring

Adjusts the picture size.

13 Focus ring

Adjusts the picture focus.

14 Security lock

Connects to an optional security cable (from Kensington).

Web page address:

<http://www.kensington.com/>

15 Security bar

An anti-theft chain or wire (commercially available) can be connected to it. First remove the cover attached in the factory before use. Refer to “Dimensions” (page 65) for the shapes.

16 Speaker

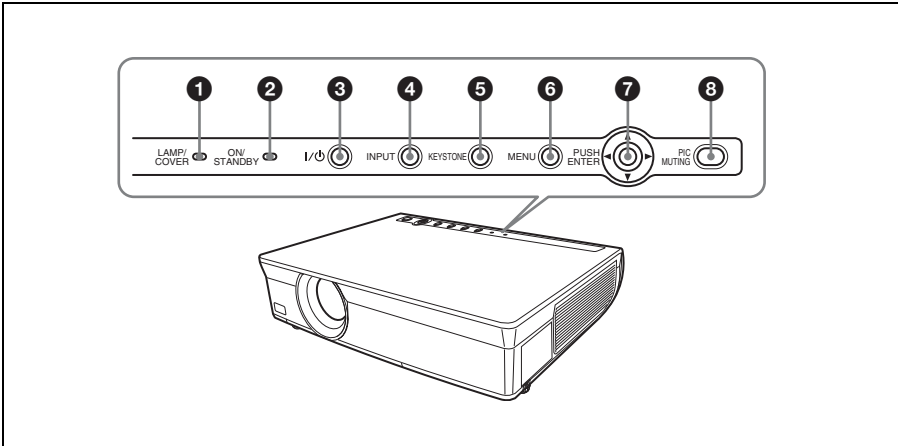

1 LAMP/COVER indicators

Flashes in orange under the following conditions:

- A reception rate of 2 flashes when the lamp cover or air filter cover is not secured firmly.
- A reception rate of 3 flashes when the lamp has reached the end of its life or reaches a high temperature.

For details, see page 51.

2 ON/STANDBY indicator

Lights up or flashes under the following conditions:

- Lights in red when the AC power cord is plugged into a wall outlet. Once the projector is in standby mode, you can turn it on with the I/⏻ key.
- Flashes in red when the internal temperature is high or the electrical system has failed.
- Lights in green when the projector is turned on, and when it is ready to operate.
- Flashes in green from the time when the projector is turned on until the projector is ready to operate. Also, flashes in green while the cooling fan is running after the power is turned off with the I/⏻ key. The fan runs for about 60 seconds after the power is turned off.

– Lights in orange when the power saving mode is on.

For details, see page 51.

3 I/⏻ (On/Standby) key

Turns on the projector when it is in standby mode. When you push this key, the ON/STANDBY indicator flashes in green and then lights in green when the projector is ready to operate.

To turn off the power, press the I/⏻ key twice according to the message or hold the I/⏻ key for about one second.

4 INPUT key

Select the input signal. Each time you press the key the input signal switches.

5 KEYSTONE (Trapezoidal distortion correction) key

Adjusts the trapezoidal distortion of the image. Pressing this key, V KEYSTONE (Vertical trapezoidal distortion correction) adjustment menu is displayed. Use the arrow keys (▲/▼/◀/▶) for adjustment.

In the case of models VPL-CX125/CX155/CW125, Side Shot (Horizontal trapezoid distortion correction) can be adjusted by pressing this button again. Adjust it by the ▲/▼/◀/▶ key.

6 MENU key

Displays the on-screen menu. Press again to clear the menu.

7 PUSH ENTER/▲/▼/◀/▶ (Arrow) keys

Used to enter the settings of items in the menu system, select a menu, or make various adjustments.

8 PIC MUTING key

Cuts off the picture. Press again to restore the picture.

Connector Panel

Side

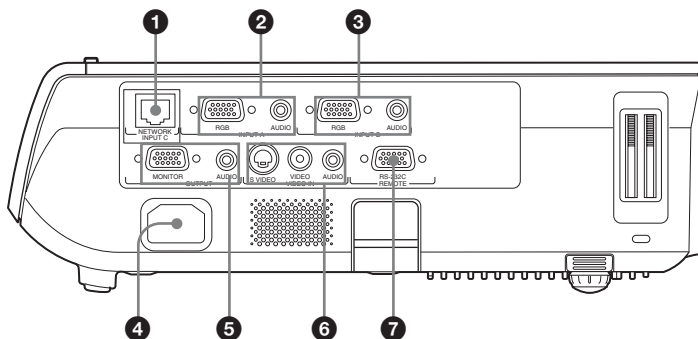

1 INPUT C (VPL-CX125/CX155/CW125 only)

NETWORK connector (RJ-45)

Connects to the LAN cable when the network function is in use.

CAUTION

For safety, do not connect the connector for peripheral device wiring that might have excessive voltage to this port. Follow the instructions for this port.

2 INPUT A Analog RGB connector (HD D-sub 15-pin, female)

Inputs a computer signal, video GBR signal, component signal, or DTV signal depending on the connected equipment. Connects to the output connector of equipment using the supplied cable or an optional cable.

For details, see “Connecting a Computer” on page 23 and “Connecting a VCR” on page 24.

AUDIO jack (stereo minijack)

To listen to sound output from a computer, connect via this jack to the audio output of the computer.

For details, see “Connecting a Computer” on page 23 and “Connecting a VCR” on page 24.

3 INPUT B Analog RGB connector (HD D-sub 15-pin, female)

Connect to external equipment such as a computer.

Connects to the monitor output of a computer using the supplied cable or an optional cable.

AUDIO jack (stereo minijack)

To listen to sound output from a computer, connect via this jack to the audio output of the computer.

4 AC IN socket

Connects the supplied AC power cord.

5 OUTPUT

MONITOR connector (HD D-sub 15-pin, female)

Connect to the video input connector of the monitor. Outputs signals from the selected channel and computer signals only from among the signals from the INPUT A or INPUT B.

AUDIO jack (stereo minijack)

Connects to external active speakers. The volume of the speakers can be controlled by the VOLUME +/- keys on the Remote Commander.

When INPUT A or B is selected, the sound input to the AUDIO connector of INPUT A or B is output.

When VIDEO or S VIDEO is selected, the sound input to the AUDIO input connector of VIDEO IN is output.

6 VIDEO IN (Video input)

Connects to external video equipment.

S VIDEO jack (mini DIN 4-pin)

Connects to the S video output (Y/C video output) of video equipment.

VIDEO jack (phono type)

Connects to the composite video output of video equipment.

AUDIO jack

Connect to the audio output of video equipment.

7 REMOTE

RS-232C connector (D-sub 9-pin, female)

Connects to a computer to operate the projector from the computer.

Remote Commander

The supplied remote commander differs according to the model. Refer to the relevant page.

VPL-CX125/CX155/CW125: Page 17.

VPL-CX100/CX120/CX150: Page 19.

VPL-CX125/CX155/CW125

The keys that have the same names as those on the control panel function identically.

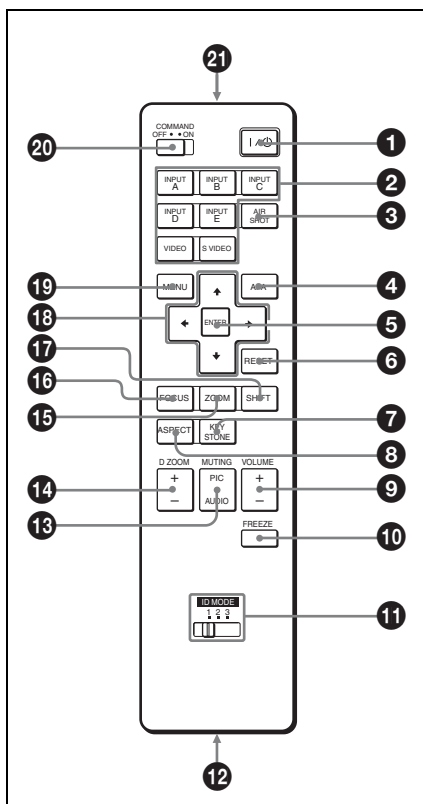

1 I/⏻ (On/Standby) key

2 INPUT A/B/C/D/E keys

Selects the input signal output from the connector of the same name as those of the Remote Commander. INPUT D key and INPUT E key are not used in this model.

③ AIR SHOT key

Displays the Network Presentation Home.

For details, see Operating Instructions for Network (stored on the CD-ROM).

④ APA (Auto Pixel Alignment) key

Automatically adjusts a picture to its clearest while a signal is input from a computer.

For details, see “Smart APA” in “The Function Menu” on page 39.

⑤ ENTER key

⑥ RESET key

Resets the value of an item to its factory preset value or returns the enlarged image with D ZOOM key to its original size. This key functions when the menu or a setting item is displayed on the screen.

⑦ KEYSTONE (Trapezoidal distortion correction) key

⑧ ASPECT key

Select the aspect ratio of the picture. Each time you press this key the aspect ratio changes according to the input signals.

⑨ VOLUME +/- keys

⑩ FREEZE key

Freezes the projected picture. To cancel the frozen picture, press the key again. This function is available when the PC signal is input.

⑪ ID MODE 1/2/3 keys

When you apply the same identification number as the projector to a Remote Commander you can easily adjust or control each projector with a Remote Commander whenever you use two or more projectors in one room.

For details, see “ID Mode” in the Installation menu on page 42.

⑫ CONTROL S OUT jack (stereo mini-jack)

This function is not provided in this projector.

⑬ MUTING keys

Cut off the picture and sound.

- **PIC:** Cuts off the picture. Press again to restore the picture.
- **AUDIO:** Press to temporarily cut off the audio output from the speaker. Press again, or press the VOLUME+ key to restore the sound.

⑭ D ZOOM (Digital Zoom) +/- key

Enlarges the image at a desired location on the screen. This function is available when the PC signal is input.

⑮ ZOOM +/- keys

This function is not provided in this projector.

⑯ FOCUS +/- keys

This function is not provided in this projector.

⑰ SHIFT +/- keys

This function is not provided in this projector.

⑱ ↑/↓/←/→ keys (Arrow)

These keys have same function as the ▲/▼/◀/▶ keys on the Control Panel of the main unit.

⑲ MENU key

⑳ COMMAND ON/OFF switch

When this switch is set to OFF, the keys on the Remote Commander do not function. This saves battery power.

㉑ Infrared transmitter

To install batteries

- 1 Push and slide the lid to open it, then install the two size AA (R6) batteries (supplied) with the correct polarity.

While pressing the lid, slide it.

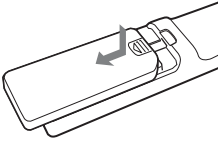

Be sure to install the battery from the ⊖ side.

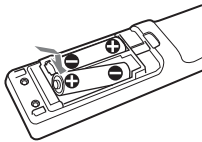

- 2 Replace the lid.

Notes on Remote Commander operation

- Make sure that nothing obstructs the infrared beam between the Remote Commander and the remote control detector on the projector. Direct the Remote Commander toward the front or rear remote control detector.
- The operation range is limited. The shorter the distance between the Remote Commander and the projector is, the wider the angle within which the commander can control the projector becomes.

VPL-CX100/CX120/CX150

The keys that have the same names as those on the control panel function identically.

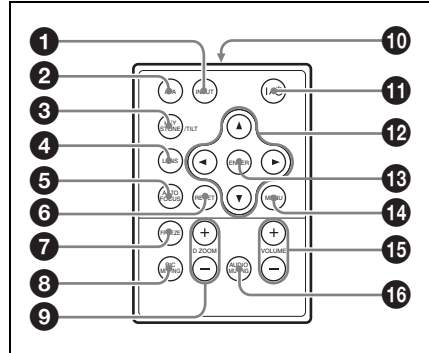

- 1 **INPUT key**
- 2 **APA (Auto Pixel Alignment) key**
Automatically adjusts a picture to its clearest while a signal is input from a computer.
For details, see “Smart APA” in “The Function Menu” on page 39.
- 3 **KEYSTONE (Trapezoidal distortion correction) key**
- 4 **LENS key**
This function is not provided in this projector.
- 5 **AUTO FOCUS key**
This function is not provided in this projector.
- 6 **RESET key**
Resets the value of an item to its factory preset value or returns the enlarged image with D ZOOM key to its original size. This key functions when the menu or a setting item is displayed on the screen.
- 7 **FREEZE key**
Freezes the projected picture. To cancel the frozen picture, press the key again. This function is available when the PC signal is input.

8 PIC MUTING key

9 D ZOOM (Digital Zoom) +/- key

Enlarges the image at a desired location on the screen.

10 Infrared transmitter

11 I/⏻ (On/Standby) key

12 ▲/▼/◀/▶ (Arrow) keys

13 ENTER key

14 MENU key

15 VOLUME +/- keys

16 AUDIO MUTING key

Press to temporarily cut off the audio output from the speaker and from the AUDIO jack of the OUTPUT. Press again or press the VOLUME + key to restore the sound.

Before using the Remote Commander

Pull out the clear film from the lithium battery holder.

To replace a battery

1 Release the lock of the lithium battery holder by picking it, and pull out the holder from the Remote Commander.

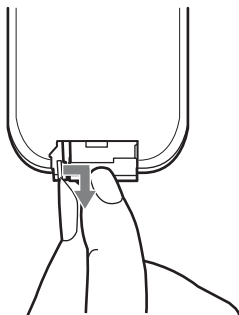

2 Install the lithium battery.

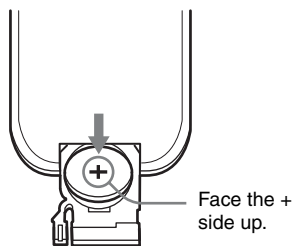

3 Put the lithium battery holder back into the Remote Commander.

Notes on the lithium battery

- A button type lithium battery (CR2025) is used in the Remote Commander. Do not use batteries other than CR2025.
- Keep the lithium battery out of the reach of children.
- Should the battery be swallowed, immediately consult a doctor.

Notes on Remote Commander operation

- Make sure that nothing obstructs the infrared beam between the Remote Commander and the remote control detector on the projector. Direct the Remote Commander toward the remote control detector.
- The operation range is limited. The shorter the distance between the Remote Commander and the remote control detector is, the wider the angle within which the commander can control the projector becomes.

Installing the Projector

The distance between the lens and the screen varies depending on the size of the projected image. Use the following table as a guide.

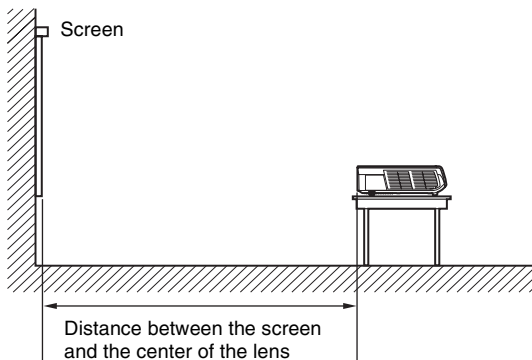

VPL-CX100/CX120/CX125/CX150/CX155

(When an XGA signal is input)

Unit: m (feet)

Projected image size (diagonal) (inches)	40	60	80	100	120	150	180	200	250	300
Minimum Distance	1.2 (3.9)	1.8 (5.9)	2.4 (7.9)	3.0 (9.8)	3.6 (11.8)	4.5 (14.8)	5.4 (17.7)	6.0 (19.7)	7.5 (24.6)	9.1 (29.9)
Maximum Distance	1.4 (4.6)	2.1 (6.9)	2.8 (9.2)	3.5 (11.5)	4.1 (13.5)	5.2 (17.1)	6.2 (20.3)	6.9 (22.6)	8.7 (28.5)	10.4 (34.1)

There may be a slight difference between the actual value and the design value shown in the table above.

VPL-CW125

(When "Aspect" on the Signal menu is set to "Full 2")

Unit: m (feet)

Projected image size (diagonal) (inches)	40	60	80	100	120	150	180	200	250	300
Minimum Distance	1.3 (4.3)	1.9 (6.2)	2.6 (8.5)	3.2 (10.5)	3.9 (12.8)	4.9 (16.1)	5.9 (19.4)	6.5 (21.3)	8.1 (26.6)	9.8 (32.2)
Maximum Distance	1.5 (4.9)	2.2 (7.2)	3.0 (9.8)	3.7 (12.1)	4.5 (14.8)	5.6 (18.4)	6.7 (22.0)	7.5 (24.6)	9.4 (30.8)	11.3 (37.1)

There may be a slight difference between the actual value and the design value shown in the table above.

Notes for VPL-CW125 only

- When “Aspect” on the Signal menu is set to other than “Full 2”, black bands appear at the top and bottom or right and left of the screen.
- When “Aspect” in the Signal menu is set to “4:3”, the projected image size (diagonal) will be approximately 84 % of “Full 2” size.
- When “Aspect” in the Signal menu is set to “16:9”, the projected image size (diagonal) will be approximately 99 % of “Full 2” size.

For details on installation, see “Installation Diagram” on page 59.

Connecting the Projector

When you connect the projector, make sure to:

- Turn off all equipment before making any connections.
- Use the proper cables for each connection.
- Insert the cable plugs firmly; loose connections may increase noise and reduce performance of picture signals. When pulling out a cable, be sure to pull it out by the plug, not the cable itself.

For VPL-CX125/CX155/CW125, when connecting to a LAN using a LAN cable, see “Operating Instructions for Network” stored on the CD-ROM.

Connecting a Computer

This section describes how to connect the projector to a computer.

For more information, refer to the computer’s instruction manual.

To connect a computer

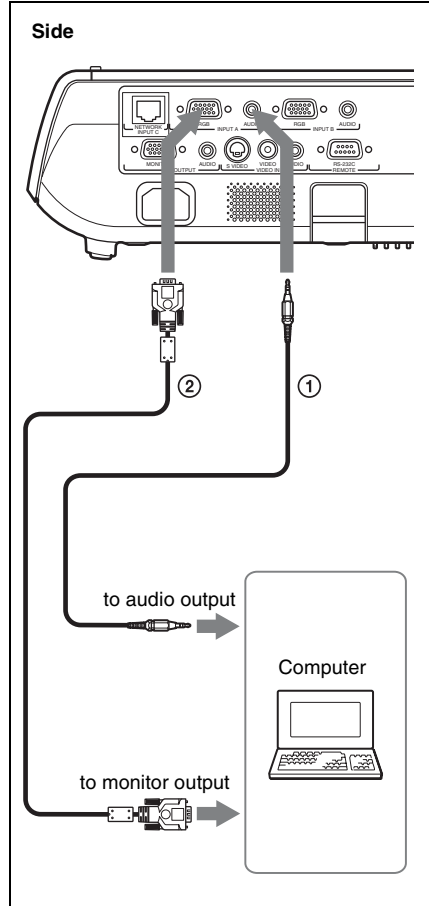

- ① Stereo audio connecting cable (not supplied)
(Use a no-resistance cable.)
- ② HD D-sub 15-pin cable

Notes

- The projector accepts VGA, SVGA, XGA, WXGA, SXGA and SXGA+ signals. However, we recommend that you set the output mode of your computer to XGA (VPL-CX100/CX120/CX125/CX150/

CX155) or WXGA (VPL-CW125) for the external monitor.

- If you set your computer, such as a notebook computer, to output the signal to both your computer's display and the external monitor, the picture of the external monitor may not appear properly. Set your computer to output the signal to only the external monitor.

For details, refer to the operating instructions supplied with your computer.

Note

To connect a Macintosh computer equipped with a video output connector of a type having two rows of pins, use a commercially available plug adaptor.

Connecting a VCR

This section describes how to connect the projector to a VCR.

For more information, refer to the instruction manuals of the equipment you are connecting.

To connect to a video or S video output connector

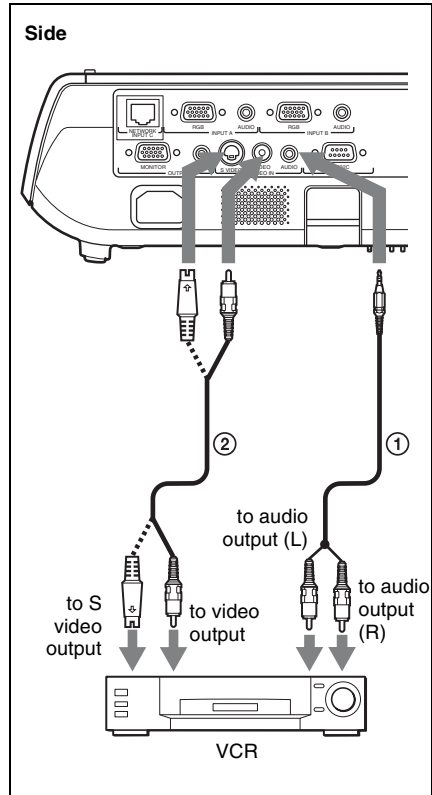

- ① Stereo audio connecting cable (not supplied)
(Use a no-resistance cable.)
- ② Video cable (not supplied) or S-Video cable
(not supplied)

To connect to a video GBR/ Component output connector

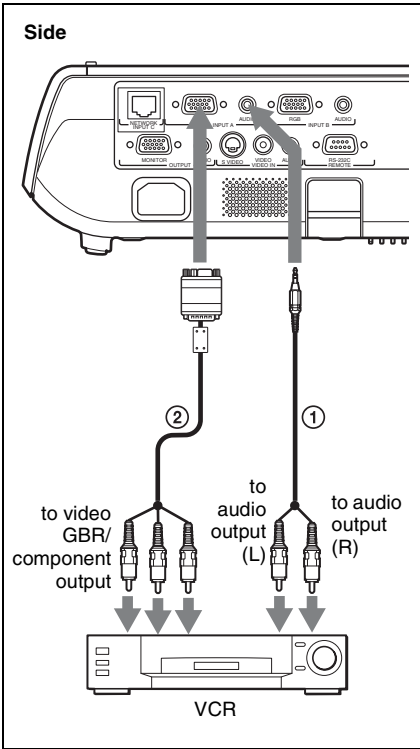

- ① Stereo audio connecting cable (not supplied)
(Use a no-resistance cable.)
- ② Signal Cable (not supplied)
HD D-sub 15-pin (male) ↔ 3 × phono jack

Notes

- Set the aspect ratio using “Aspect” on the Signal menu according to the input signal.
- When you connect the projector to a video GBR output connector, select “Video GBR” or when you connect the projector to a component output connector, select “Component” with the “Input-A Signal Sel.” setting on the Setup menu.

Projecting

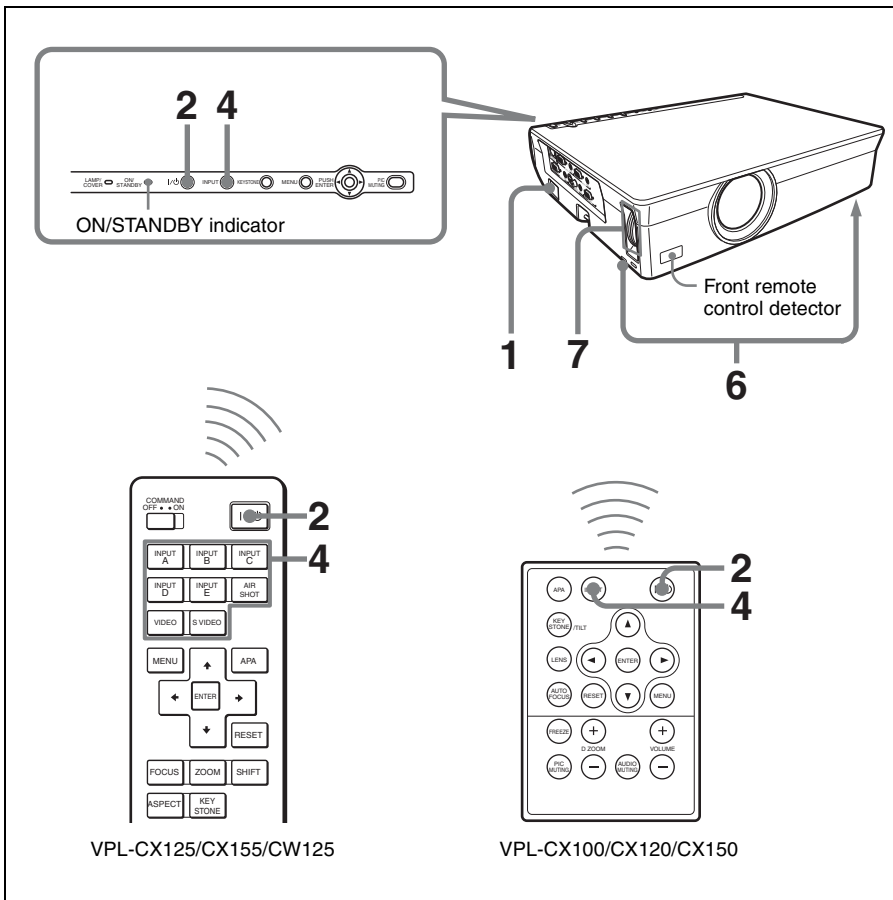

- 1** Plug the AC power cord into a wall outlet, then connect all equipment. The ON/STANDBY indicator lights in red and the projector goes into standby mode.
- 2** Press the I/⏻ key. The ON/STANDBY indicator flashes in green, and then lights in green.
- 3** Turn on the equipment connected to the projector.

- 4** Select the input source.

To operate with the Remote Commander of VPL-CX125/CX155/CW125

You can select directly the input signal you want to project by pressing one key from among INPUT A, B, C, AIR SHOT, VIDEO or S VIDEO on the Remote Commander.

To operate with the Control Panel or the Remote Commander of VPL-CX100/CX120/CX150

Each time you press the INPUT key, the input signal switches as follows:

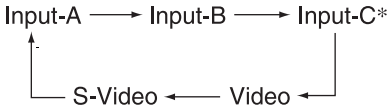

* VPL-CX125/CX155/CW125 only

To input from	Press INPUT to display
Computer, Component, Video GBR etc. connected to the INPUT A connector	Input-A
Computer, etc. connected to the INPUT B connector	Input-B
Computer connected to LAN to use the network presentation function	Input-C (VPL-CX125/CX155/CW125 only)
Video equipment connected to the VIDEO input connector	Video
Video equipment connected to the S VIDEO input connector	S-Video

Notes

- If “Auto Input Search” is set to “On,” the projector searches for the signals from the connected equipment and displays the input channel where the input signals are found.
- When the no signal is input to the VPL-CX125/CX155/CW125, “Input-C” is selected.

For details, see “Auto Input Search” in the Function Menu on page 39.

5 Switch the equipment connected to output to the projector.

Depending on the type of your computer, for example a notebook, or an

all-in-one LCD type, you may have to switch the computer to output to the projector by pressing certain keys (e.g., / , , etc.), or by changing your computer’s settings.

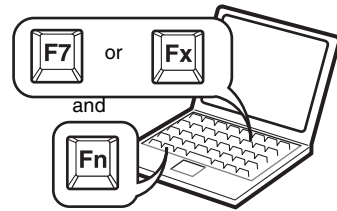

Note

The key used for switching the computer to output to the projector varies depending on the type of computer.

6 Adjust the upper or lower position of the picture.

Use the adjuster to adjust the picture position.

Using the adjuster

- ① Lift the projector while pressing the Adjuster adjustment button.
- ② Adjust the tilt of the projector.
- ③ Release the Adjuster adjustment button.
- ④ When fine-tuning is necessary, turn the Adjuster right and left.

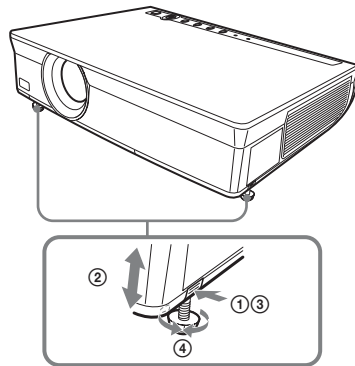

Notes

- When you adjust the tilt of the projector with the adjuster, the V keystone

adjustment is performed at the same time. If you do not want to perform the automatic keystone adjustment, set the “V Keystone” to “Manual.” (See page 41.)

- If you set the “V Keystone” to “Auto,” the “V Keystone” correction is automatically adjusted. However, it may not be perfectly adjusted depending on the room temperature or the screen angle. In this case, adjust it manually. Press the KEYSTONE key to “V Keystone” displays on the screen, and adjust the value with the ▲/▼/◀/▶ keys.
- Be careful not to let the projector down on your fingers.
- Do not push hard on the top of the projector with the adjuster extended. It may cause a malfunction.

7 Adjust the size of the picture and the focus.

Adjust the picture size using the Zoom ring and adjust the picture focus using the Focus ring.

Turning Off the Power

- 1 Press the I/⏻ key.
“POWER OFF? Please press I/⏻ key again.” appears to confirm that you want to turn off the power.

Note

The message disappears if you press any key other than the I/⏻ key, or if you do not press any key for five seconds.

- 2 Press the I/⏻ key again.
The ON/STANDBY indicator flashes in green and the fan continues to run to reduce the internal heat. During this time, you will not be able to light up the ON/STANDBY indicator again with the I/⏻ key.
- 3 Unplug the AC power cord from the wall outlet after the fan stops running and the ON/STANDBY indicator lights in red. (Except when using the Direct Power On/ Off function.)

When you cannot confirm the on-screen message

When you cannot confirm the on-screen message under certain conditions, you can turn off the power by holding the I/⏻ key for about one second instead of the steps 1 and 2 above.

Selecting the Menu Language

You can select one of fifteen languages for displaying the menu and other on-screen displays. The factory setting is English. To change the menu language, proceed as follows:

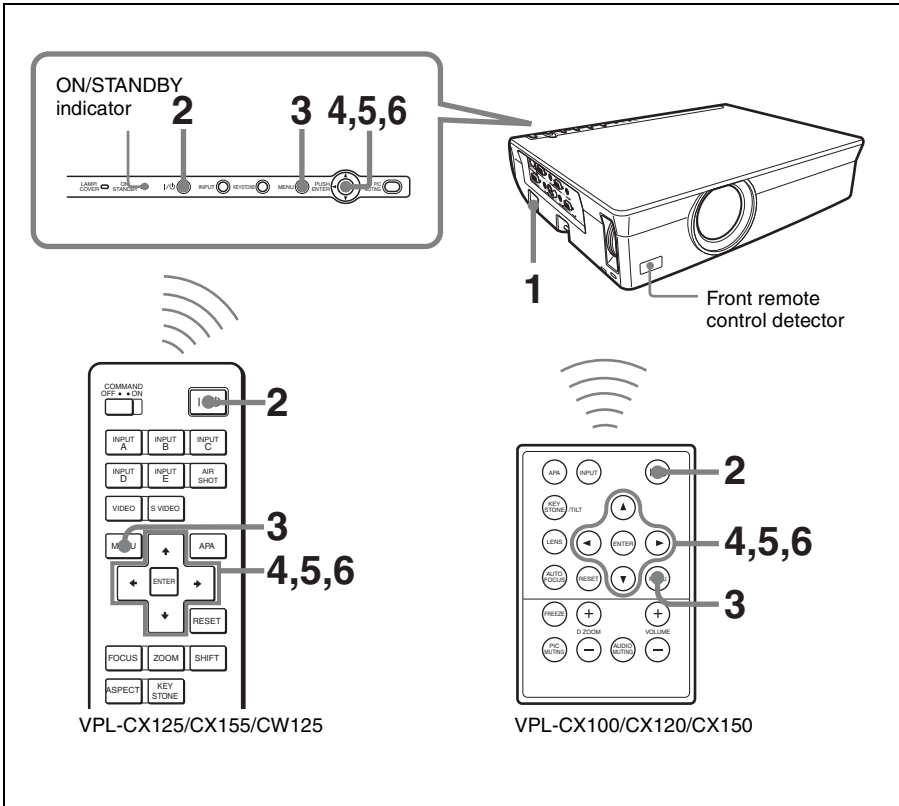

Convenient Functions

- 1** Plug the AC power cord into a wall outlet.
- 2** Press the I/ON key to turn on the projector.
The ON/STANDBY indicator flashes in green, and then lights in green.
- 3** Press the MENU key.
The menu appears.
The menu currently selected is shown as a yellow button.

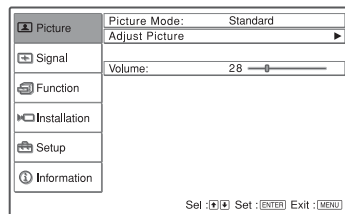

- 4** Press the ▲ or ▼ key to select the Setup menu, then press the ► or ENTER key.

The selected menu appears.

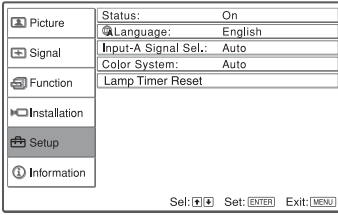

- 5 Press the ▲ or ▼ key to select “Language,” then press the ► or ENTER key.

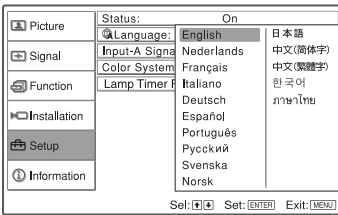

- 6 Press the ▲, ▼, ◀ or ▶ key to select a language, then press the ENTER key. The menu changes to the selected language.

To clear the menu

Press the MENU key.

The menu also disappears automatically if a key is not pressed for one minute.

Security Lock

The projector is equipped with a security lock function. When you turn the power of the projector on, you are required to input the previously set password. If you do not input the correct password, you will not be able to project the picture.

Notes

- When the security lock becomes effective, you are required to input the password only when you turn the projector on after disconnecting or reconnecting the cable.
- You will not be able to use the projector if you forget your password and the password administrator is not available. Be please aware that using the security lock can prevent valid usage in such cases.

To use the security lock

- 1 Press the MENU key and then, on the Function menu, turn on the “Security Lock” setting.
- 2 Enter the password. Use the MENU, ▲/▼/◀/▶, and ENTER keys to enter the four-digit password. (The default initial password setting is “ENTER, ENTER, ENTER, ENTER.” After this is entered you can put in your own password. Therefore, when you use this function for the first time, please input “ENTER” four times.)

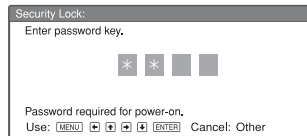

Next, the screen for entering the new password is displayed. (Enter the password on this screen even if you want to keep the current password.)

Enter the password on this screen.

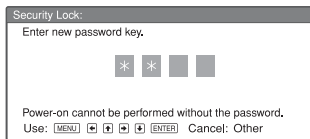

Note

If you call the customer service center because you have forgotten the password, you will need to be able to verify the projector's serial number and your identity. (This process may differ in other countries/regions.) Once your identity has been confirmed, we will provide you with the password.

3 Enter the password again to confirm.

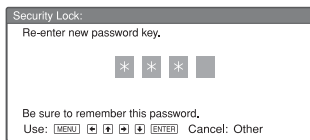

When “Security Lock enabled!” is displayed on the menu screen, the setting for security lock is completed.

If “Invalid Password!” is displayed on the menu screen, perform this procedure again from step 1.

4 Turn the main power off and disconnect the AC power cord.

The security lock is set to on, then it becomes effective. The screen used for entering the password is displayed when the power is turned on the next time.

Security certification

When the password screen is displayed, enter the password that was set. If you fail to enter the correct password after three tries, the projector cannot be used. In this case, press the I/O key to turn off the power.

To cancel the security lock

1 Press the MENU key, then turn off the “Security Lock” setting in the Function menu.

2 Enter the password.
Enter the password that was set.

Other Functions

Direct Power On/Off Function

If you will be using a circuit breaker to turn the power for the entire system on and off, set the direct power on function to “On.” You can turn the power on/off without pressing the power key on the projector.

Effective Tools for Your Presentation

To enlarge the image (Digital Zoom function)

You can select a section of the image to enlarge. This function works when a signal from a computer is input. This function does not work when a video signal is input.

- 1 Project a normal image, and press the D ZOOM + key on the Remote Commander.

The digital zoom icon appears in the center of the image.

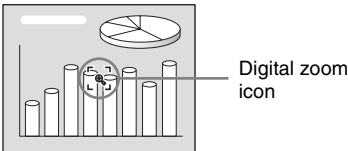

- 2 Move the icon to the point on the image you want to enlarge. Use the arrow key (▲/▼/◀/▶) to move the icon.
- 3 Press the D ZOOM + key again.
The portion of the image where the icon is located is enlarged. The enlargement ratio is displayed on the screen for a few seconds.

By pressing the + key repeatedly, the image size (ratio of enlargement: max. 4 times) increases.

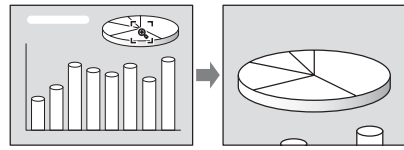

Use the arrow key (▲/▼/◀/▶) to scroll the enlarged image.

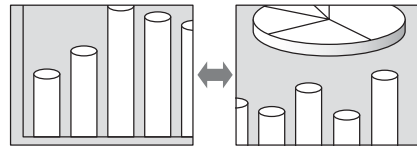

To return the image to its original size

Press the D ZOOM – key.

Just pressing the RESET key returns the image back to its original size immediately.

To freeze the image projected (Freeze function)

Press the FREEZE key. “Freeze” appears when the key is pressed. This function works when a signal from a computer is input.

To restore the original screen, press the FREEZE key again.

Controlling the Computer Using a Presentation Tool, RM-PJK1 (not supplied) (When Using the Network Presentation Function) (VPL-CX125/CX155/CW125 only)

When you are using the network presentation function to project the picture from a computer, you can perform some operations for a slide show using a presentation tool (not supplied). The following keys on the presentation tool are usable.

Key	Function
LASER*	Emits a laser beam.
⇄ SLIDE ⇄	Changes the slides in the forward/backward direction.
B	Displays/cancels a black screen during the slide show.

* Even if the network presentation function is not used, the LASER key can be used.

Notes

- If there is any obstruction between the presentation tool and the remote control detector on the projector, the presentation tool may not function properly.
- A black screen may not be displayed even if you press the “B” key depending on the operating system (OS) of the language of your computer.
- When you use the presentation tool, set “ID Mode” in the Installation menu to “All” or “1.”

Using a MENU

The projector is equipped with an on-screen menu for making various adjustments and settings. Some of the adjustable/setting items are displayed in a pop-up menu, in a setting menu or adjustment menu with no main menu, or in the next menu window. If you select an item name followed by an arrow (►), the next menu window with the setting items appears.

To change the on-screen menu language, see “Selecting the Menu Language” on page 29.

Display items

There are explanations for VPL-CX100, VPL-CX120, VPL-CX125, VPL-CX150, VPL-CX155 and VPL-CW125 all together in this manual. Be please aware that VPL-CX155 is mainly used for explanation of the display, and there may be an item that is not displayed due to the model.

- 1 Press the MENU key.
The menu appears.

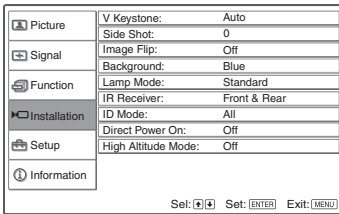

- 2 Use the ▲ or ▼ key to select a menu, then press the ► or ENTER key.
The items that can be set or adjusted with the selected menu appear. The item presently selected is shown in yellow.
- 3 Select an item.
Use the ▲ or ▼ key to select the item, then press the ► or ENTER key.
The setting items are displayed in a pop-up menu, in a setting menu, in an adjustment menu or in the next menu window.

Pop-up menu

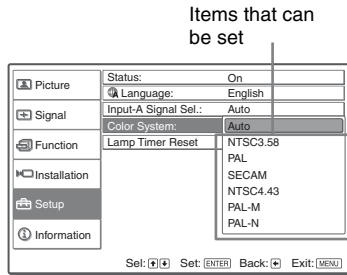

Setting menu

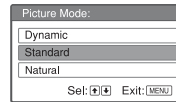

Adjustment menu



Next menu window

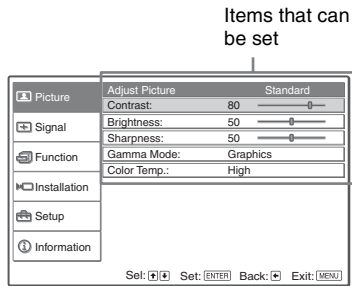

- 4 Make the setting or adjustment of an item.
 - **When changing the adjustment level:**
 - To increase the number, press the ▲ or ► key.
 - To decrease the number, press the ▼ or ◀ key.
 - Press the ENTER key. The setting or adjustment done is stored and the previous screen is restored.
 - **When changing the setting:**
 - Press the ▲ or ▼ key to select the setting.
 - Press the ENTER or ► key to restore the previous screen.

To clear the menu

Press the MENU key.

The menu disappears automatically if a key is not pressed for one minute.

To reset items that have been adjusted

Select the item that you want to reset, and press the RESET key on the Remote Commander.

“Complete!” appears on the screen and **the setting of the item that you have selected is reset to its factory preset value.**

Items that can be reset are:

- “Contrast,” “Brightness,” “Color,” “Hue” and “Sharpness” on the “Adjust Picture...” menu of the Picture menu
- “Dot Phase,” “H Size,” and “Shift” on the “Adjust Signal...” menu of the Signal menu
- “Side Shot” on the Installation menu (VPL-CX125/CX155/CW125 only)

Storage of the settings

The settings are automatically stored in the projector memory when the ENTER key is pressed.

Note

The resetting item of the Lamp timer setting is not memorized.

If no signal is input

If there is no input signal, “Cannot adjust this item.” appears on the screen.

Unadjustable items

Items that cannot be adjusted, depending on the input signal, are not displayed on the menu.

For details, see page 45.

The Picture Menu

The Picture menu is used for adjusting the picture or volume.

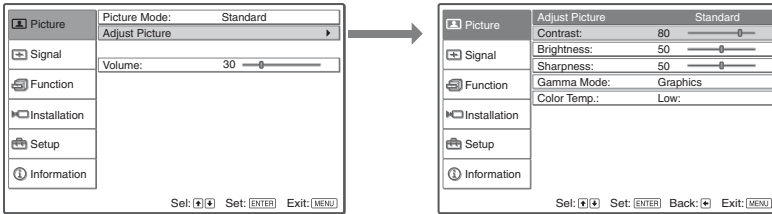

Setting items	Functions	Initial setting
Picture Mode	<p>Selects the picture mode.</p> <ul style="list-style-type: none"> • Dynamic: Emphasizes the contrast to produce a “dynamic” picture. • Standard: Normally select this setting. If the picture has roughness with the “Dynamic” setting, this setting reduces the roughness. • Natural: Selects for the color more similar to the input picture. 	Standard
Adjust Picture...	The unit can store the setting values of the following sub menu items for each “Dynamic,” “Standard” or “Natural” picture mode separately.	
Contrast	Adjusts the picture contrast.	80
Brightness	Adjusts the picture brightness.	50
Color	Adjusts color intensity.	50
Hue	Adjusts color tones. The higher the setting, the more greenish the picture becomes. The lower the setting, the more purplish.	50
Sharpness	Adjusts the picture sharpness. The higher the setting, the sharper the picture becomes. The lower the setting, the softer the picture becomes.	50
Gamma Mode	<p>Selects a gamma correction curve.</p> <ul style="list-style-type: none"> • Graphics: Improves the reproduction of halftones. Photos can be reproduced in natural tones. • Text: Contrasts black and white. Suitable for images that contain lots of text. 	Graphics
Color Temp.	<p>Select a desired color temperature to suit a picture.</p> <p>When a computer signal</p> <ul style="list-style-type: none"> • High: Makes white part bluish. • Middle: Makes white part reddish. • Low: Makes white part greenish. <p>When a video signal</p> <ul style="list-style-type: none"> • High: Turns white part to a bluish and cool tone. • Middle: Turns white part o a natural tone. • Low: Turns white part to a reddish and warm tone. 	Low
Volume	Adjusts the volume.	30

The Signal Menu

The Signal menu is used to adjust the input signal.

Adjust Signal...menu (When the signal is input from a computer)

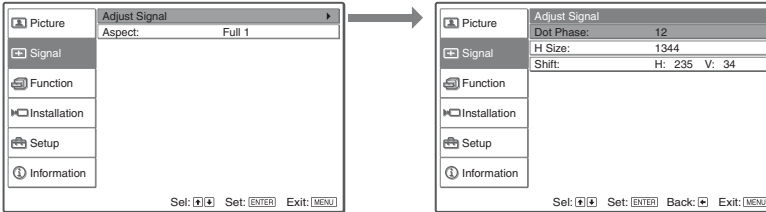

Setting items	Functions	Initial setting
Adjust Signal...		
Dot Phase	Adjusts the dot phase of the LCD panel and the signal output from a computer. Adjust the picture further for finer picture after the picture is adjusted by pressing the APA key.	Set according to the input signal
H Size	Adjusts the horizontal size of a picture output from a computer. Adjust the setting according to the dots of the input signal. For details, see page 57.	Set according to the input signal
Shift	Adjusts the position of the picture. H adjusts the horizontal position of the picture. V adjusts the vertical position of the picture. As the setting for H increases, the picture moves to the right, and as the setting decreases, the picture moves to the left. As the setting for V increases, the picture moves up, and as the setting decreases, the picture moves down. Use the ◀ or the ▶ key to adjust the horizontal position and the ▲ and ▼ key for the vertical position.	Set according to the input signal
Aspect (When the video signal is input)	You can set the aspect ratio of the picture to be displayed for the current input signal. This item is enabled only when an video signal (preset memory numbers 1 to 11) is input. <ul style="list-style-type: none"> • Full 2: The original image is projected fully in the window. • 4:3: Select to view a picture with normal 4:3 aspect ratio. • 16:9: Select to view a picture squeezed. 	Set according to the input signal

Setting items	Functions	Initial setting
Aspect (When the PC signal is input)	<p>You can set the aspect ratio of the picture to be displayed for the current input signal. This item is enabled only when an PC signal (preset memory numbers 21 to 63) is input.</p> <ul style="list-style-type: none"> • Full 1: Displays a picture vertically or horizontally to fill the screen without changing the aspect ratio of the original picture. • Full 2: The original image is projected fully in the window. • Normal: Displays the picture while matching one pixel of input picture element to that of the LCD. The picture will be clear but the picture size will be smaller. • 4:3: Makes the aspect ratio 4:3. • 16:9: Makes the aspect ratio 16:9. 	Set according to the input signal

Note

Note that if the projector is used for profit or for public viewing, modifying the original picture by switching to the wide mode may constitute an infringement of the rights of authors or producers, which are legally protected.

About the Preset Memory No.

This projector has 43 types (VPL-CX100/CX120/CX125/CX150/CX155) or 44 types (VPL-CW125) of preset data for input signals (the preset memory). When a preset signal is input, the projector automatically detects the signal type and recalls the data for the signal from the preset memory to adjust it to an optimum picture. The memory number and signal type of that signal are displayed on the Information menu (see page 44). You can also adjust the preset data through the Signal menu.

This projector has 20 types of user memories for each of Input A and Input B into which you can save the setting of the adjusted data for an unpreset input signal.

When an unpreset signal is input for the first time, a memory number is displayed as 0.

When you adjust the data of the signal using the Signal menu, it will be registered in the projector. If more than 20 user memory items are registered, the newest memory always overwrites the oldest one.

See the chart on page 58 to find if the signal is registered in the preset memory.

Since the data for the following signals is recalled from the preset memory, you can

use these preset data items by adjusting “H Size.” Make finer adjustments by adjusting “Shift.”

Signal	Memory No.	SIZE
Super Mac-2	37	1312
SGI-1	37	1320
Macintosh 19"	39	1328
Macintosh 21"	41	1456
Sony News	47	1708
PC-9821 1280 × 1024	47	1600
WS Sunmicro	48	1664

The Function Menu

The Function menu is used for changing the settings of the projector.

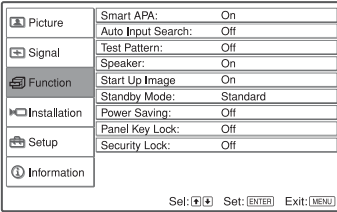

Setting items	Functions	Initial setting
Smart APA	The APA (Auto Pixel Alignment) automatically adjusts “Dot Phase,” “H Size” and “Shift” on the Signal menu for the input signal from a computer. <ul style="list-style-type: none"> • On: When a signal is input from a computer, the APA functions automatically so that the picture can be seen clearly. Once the specified input signal has been adjusted by the “Smart APA,” it will not be readjusted even when the cable is disconnected and connected again or the input channel is changed. You can adjust the picture by pressing the APA key on the Remote Commander even if “Smart APA” set to “On.” • Off: The APA functions when you press the APA key on the Remote Commander. 	On
Auto Input Search	When set to “On,” the projector detects input signals in the following order: Input A, B, *C/Video/S-Video. It indicates the input channel when the INPUT key is pressed. *VPL-CX125/CX155/CW125 only	Off
Test Pattern	When set to “On,” a test pattern is displayed on the screen during “V Keystone” or * “Side Shot” adjustment. *VPL-CX125/CX155/CW125 only	Off
Speaker	Set to “Off” to cut the sound of the internal speakers. When set to “Off,” “Speaker: Off” appears on the screen when you turn on the power.	On
Start Up Image	<ul style="list-style-type: none"> • On: Displays the Start Up Image on the screen after turning on the power. • Off: Does not displays the Start Up Image on the screen after turning on the power. 	On
Standby Mode	When set to “Low”, the power consumption is set to low in standby mode.	Standard

Setting items	Functions	Initial setting
Power Saving	<p>Selects the Power Saving mode.</p> <ul style="list-style-type: none"> • Lamp off: The lamp goes off if no signal is input for 10 minutes. The lamp lights again when a signal is input or any key is pressed. • Standby: The projector goes into Standby mode if no signal is input for 10 minutes. To use it, turn on the power again. • Off: The projector does not go into Power Saving mode. 	Off
Panel Key Lock	<p>Locks all the control panel keys on the top of the projector so that the projector can be operated only with the Remote Commander.</p> <p>To lock the control panel keys, set to "On."</p> <p>When it is set to "On," keeping the I/⏻ key on the control panel pressed for 10 seconds turns the projector on when it is in standby mode, and turns the projector to standby mode when the power is on. If you press and hold the MENU key for about 10 seconds when the power is on, the lock will be released and "Panel Key Lock" is automatically set to "Off."</p>	Off
Security Lock	<p>Turns on the projector's security lock function. When set to "On," turns on the security lock function, which locks the projector once a password has been set.</p> <p><i>For details, see "Security Lock" on page 30.</i></p>	Off

Notes

- Press the APA key when the full image is displayed on the screen. If the projected image includes a black portion around it, the APA function will not work properly and some parts of the image may not be displayed on the screen.
- You can cancel the adjustment by pressing the APA key again while "Adjusting" appears on the screen.
- The picture may not be adjusted properly depending on the type of input signal.
- While WXGA signal (1280×768/1360×768) is being input, the adjustment process of when Smart APA is set to "On" may differ from when the APA key on the remote commander is pressed.
- Adjust the "Dot Phase," "H Size," and "Shift" items on the Signal menu when you adjust the picture manually.
- When "Standby mode" is set to "Low", the network presentation and the network control functions cannot be used in standby mode.

The Installation Menu

The Installation menu is used for changing the settings of the projector.

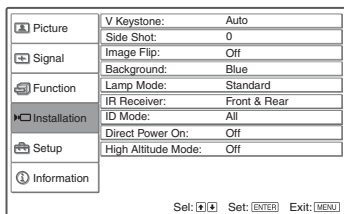

Setting items	Functions	Initial setting
V Keystone	<p>Corrects the trapezoidal distortion caused by the projection angle. Select “Auto” for automatic correction, or “Manual” for manual correction using the ▲/▼/◀/▶ keys.</p> <p>When the bottom of the trapezoid is longer than the top : Sets a lower value.</p> <p>When the top of the trapezoid is longer than the bottom : Sets a higher value.</p>	Auto
Side Shot (VPL-CX125/ CX155/CW125 only)	<p>Corrects the horizontal trapezoidal distortion of the picture using the ▲/▼/◀/▶ keys.</p> <p>When the right side is longer than the left side Set to a higher value (+ direction).</p> <p>When the left side is longer than the right side Set to a lower value (– direction).</p> <p>Set the adjustment level to “0” if you want to adjust the picture more widely using “V Keystone” only.</p>	0
Image Flip	<p>Flips the image on the screen horizontally and/or vertically.</p> <ul style="list-style-type: none"> • Off: The image does not flip. • HV: Flips the image horizontally and vertically. • H: Flips the image horizontally. • V: Flips the image vertically. 	Off
Background	<p>Selects the background color of the screen when no signal is input to the projector. Select “Black” or “Blue.”</p> <p>Normally, set to “Blue.”</p>	Blue
Lamp Mode	<p>Sets the lamp brightness used during the projection.</p> <ul style="list-style-type: none"> • High: Illuminates the projected image brightly. • Standard: Reduces fan noise and power consumption. The brightness of the projected image will be lower compared with the “High” setting. 	Standard
IR Receiver	<p>Selects the remote control detectors (IR Receiver) on the front and rear of the projector.</p> <ul style="list-style-type: none"> • Front & Rear: Activates both the front and rear detectors. • Front: Activates the front detector only. • Rear: Activates the rear detector only. 	Front & Rear

Setting items	Functions	Initial setting
ID Mode (VPL-CX125/CX155/CW125 only)	Assigns an ID number (1 to 3) to the projector when you want control two or more projectors individually with the supplied Remote Commander. When this item is set to "1," you can control the projector with the Remote Commander with the ID MODE key set to "1." When it is set to "All," you can control all the projectors with the Remote Commander independently of the ID MODE keys of the Remote Commander.	All
Direct Power On	Set to "On" if you are using a circuit breaker to turn the power on/off the entire system. You can turn the power on/off without pressing the power key on the projector.	Off
High Altitude Mode	Set to "On" when the projector is used at an altitude of 1,500 m or higher.	Off

Notes

- The auto V Keystone adjustment may not correct the trapezoidal distortion perfectly, depending on the room temperature or the screen angle.
- If you need fine adjustment when V Keystone is set to "Auto", press the KEYSTONE key on the control panel or the remote commander, and change the value. The setting mode will be temporarily changed to "Manual" from "Auto".
- If you want restore the "Auto" setting, first switch the V Keystone setting to "Manual", then return it to "Auto".
- When you want to apply the fine adjustment value the next time, change the V Keystone setting to "Manual" from "Auto".
- If High Altitude Mode is set to "On" at an altitude under 1,500 m, the reliability of the lamp may be diminished.

The Setup Menu

The Setup menu is used for changing the menu displays.

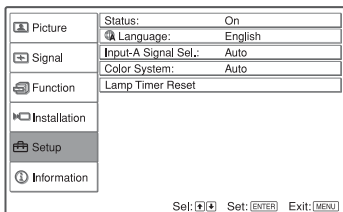

Setting items	Functions	Initial setting
Status (on-screen display)	Sets up the on-screen display. When set to “Off,” turns off the on-screen displays except for the menus, a message when the power is turned off, and warning messages.	On
Language	Selects the language used in the menu and on-screen displays. The languages available are: English, Nederlands, Français, Italiano, Deutsch, Español, Português, Русский, Svenska, Norsk, 日本語, 中文(简体字), 中文(繁體字), 한국어 and ภาษาไทย.	English
Input-A Signal Sel.	Selects the “Auto”, “Computer,” “Component,” or “Video GBR” signal input via the INPUT A connector. When the “Auto” is selected, the type of the input signal is detected automatically. When the input signal is not displayed correctly with this item set to Auto, select the item according to the input signal.	Auto
Color System	Selects the color system of the input signal. If you select “Auto,” the projector detects the color system of the input signal automatically. If the picture is distorted or colorless, select the color system according to the input signal. When the color system of the input signal is PAL60, select “PAL.” If “Auto” is selected, the color system cannot be detected.	Auto
Lamp Timer Reset	When replacing the lamps, reset the lamp timer.	—

The Information Menu

The Information menu displays the model name, serial number, the horizontal and vertical frequencies of the input signal and the cumulated hours of usage of the lamp.

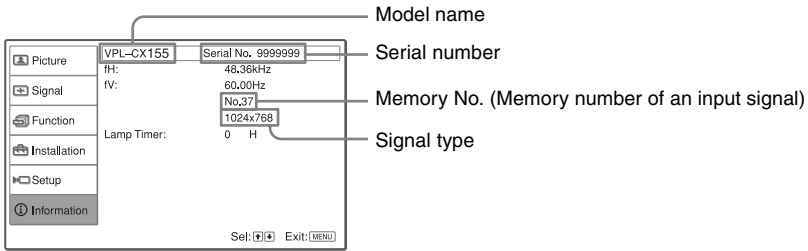

Setting items	Functions
fh	Displays the horizontal frequency of the input signal. The displayed value is approximate.
fv	Displays the vertical frequency of the input signal. The displayed value is approximate.
Memory No.	Displays the preset memory number of the input signal.
Signal type	Displays the type of the input signal.
Lamp Timer	Indicates how long the lamp has been turned on.

Notes

- Horizontal frequency and Vertical frequency may not be displayed depending on the input signal used on the projector.
- You cannot change the displays listed above.

Input signals and adjustable/setting items

Some of the items in the menus cannot be adjusted depending on the input signal as indicated in the following tables. The items that cannot be adjusted are not displayed in the menu.

Picture menu

Item	Input signal				
	Video/S-Video (Y/C)	Component	Video GBR	Computer	Network ^{*4}
Picture Mode	●	●	●	●	●
Contrast	●	●	●	●	●
Brightness	●	●	●	●	●
Color	● ^{*1}	●	●	–	–
Hue	● ^{*2}	●	●	–	–
Color Temperature	●	●	●	●	●
Sharpness	●	●	●	–	–
Gamma Mode	–	–	● ^{*3}	●	●

● : Adjustable/can be set

– : Not adjustable/cannot be set

^{*1}: Except B & W

^{*2}: NTSC_{3.58} and NTSC_{4.43} only, except B & W

^{*3}: Preset memory No. 3, 4 only.

^{*4}: VPL-CX125/CX155/CW125 only.

Signal menu

Item	Input signal				
	Video/S-Video (Y/C)	Component	Video GBR	Computer	Network ^{*6}
Aspect	●	●	●	● ^{*5}	–
Adjust Signal					
Dot Phase	–	–	–	●	–
H size	–	–	–	●	–
Shift	–	●	●	●	–

● : Adjustable/can be set

– : Not adjustable/cannot be set

^{*5}: Can be set except preset memory number 49.

^{*6}: VPL-CX125/CX155/CW125 only.

Replacing the Lamp

The lamp used as a light source is a consumable product. Replace this lamp with a new one in the following cases.

- When the lamp has burnt out or dims
- “Please replace the Lamp and clean the Filter.” appears on the screen.
- The LAMP/COVER indicator flashes in red. (Repetition rate of 3 flashes)

The lamp life varies depending on conditions of use.

Use an LMP-C200 Projector Lamp as the replacement lamp.

Use of lamps other than the LMP-C200 may cause damage to the projector.

Note

If the lamp breaks, consult with qualified Sony personnel for replacing the lamp and internal checking.

- 1 Turn off the projector, and disconnect the AC power cord from the AC outlet.

Note

When replacing the lamp after using the projector, wait at least an hour for the lamp to cool.

- 2 Open the lamp cover by loosening the three screws with a Phillips screwdriver.

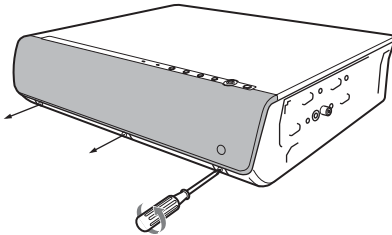

Note

If you work with the projector hung on the ceiling, hold the lamp cover so it does not fall when you release the screws.

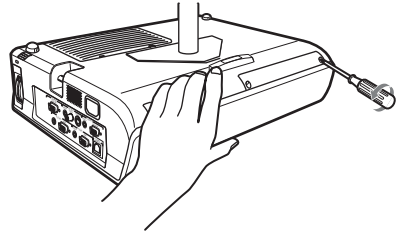

- 3 Place your fingers under the lamp cover and pull it up to remove the lamp cover.

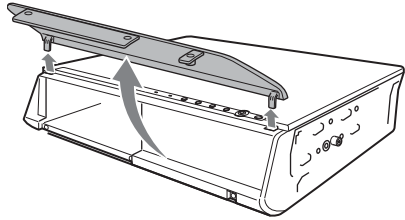

- 4 Loosen the three screws on the lamp unit with the Phillips screwdriver (1), hold the knob (2), then pull out the lamp unit.

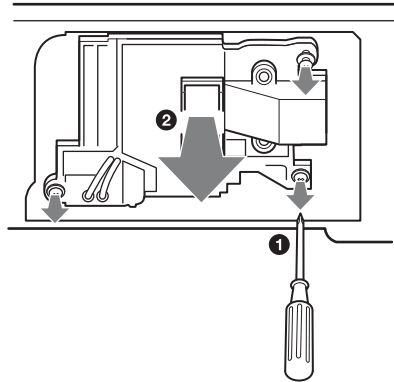

Note

Do not allow any metal objects, flammable objects, etc. into the lamp replacement slot.

- 5 Insert the new lamp all the way in until it is securely in place (1). Tighten the three screws (2).

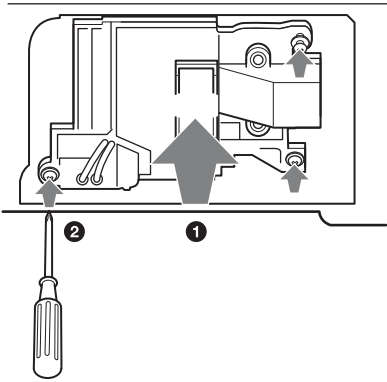

Notes

- Be careful not to touch the glass surface of the lamp.
- The power will not turn on if the lamp is not secured properly.

6 Restore the lamp cover to the original position and tighten the three screws with the Phillips screwdriver.

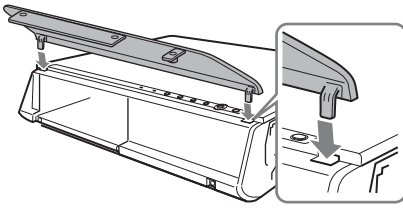

Note

Be sure to attach the lamp cover securely as it was. If not, the projector cannot be turned on. (Page 51)

- 7** Connect the power cord.
The ON/STANDBY indicator lights in red.
- 8** Press the I/⏻ key to turn the projector on.
- 9** Press the MENU key, and then select the Setup menu.

10 Select “Lamp Timer Reset”, and then press the ENTER key.

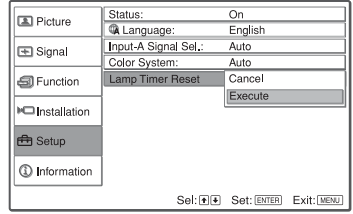

11 Select “Execute” with the ▼ key, and then press the ENTER key.

The Lamp Timer is initialized to 0, and “Change the Lamp and clean the Filter?” is displayed in the menu screen.

Refer to page 48 for “Cleaning the Air Filter”.

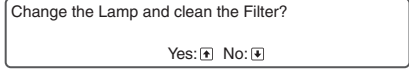

12 Select “Yes” with the ▲ key.
“Lamp Timer Reset Complete!” is displayed in the menu screen.

Note

To erase a message, press any key on the control panel of the projector or on the Remote Commander.

Disposal of the used lamp
For the customers in the USA
 Lamp in this product contains mercury. Disposal of these materials may be regulated due to environmental considerations. For disposal or recycling information, please contact your local authorities or the Electronic Industries Alliance (www.eiae.org).

Cleaning the Air Filter

The air filter should be cleaned whenever you replace the lamp.

Remove the air filter, and then remove the dust with a vacuum cleaner.

The time needed to clean the air filter will vary depending on the environment or how the projector is used.

- 1 Turn the power off and unplug the power cord.
- 2 Remove the air filter cover.

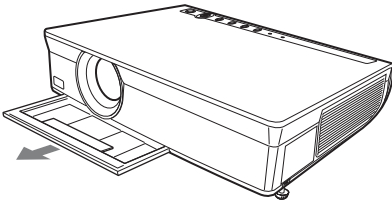

- 3 Remove the air filter from the each claws (7 positions) on the air filter cover.

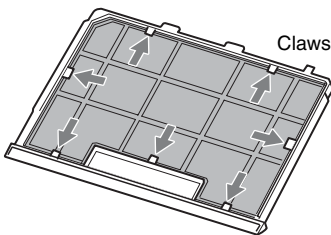

- 4 Clean the air filter with a vacuum cleaner.
- 5 Attach the air filter so that it fits into the each claws (7 positions) on the air filter covers.

Note

There is a difference between the front and rear of the air filter. Attach the air filter with the grid side facing upward as in the illustration.

- 6 Replace the air filter cover.

Notes

- If the dust cannot be removed from the air filter, replace the air filter with a new one. For details on new air filter, consult with qualified Sony personnel.
- Be sure to attach the air filter cover firmly; the power can not be turned on if it is not inserted securely. (Page 51)
- To erase a message, press any key on the control panel of the projector or on the remote commander.

Troubleshooting

If the projector appears to be operating erratically, try to diagnose and correct the problem using the following instructions. If the problem persists, consult with qualified Sony personnel.

Power

Symptom	Cause and Remedy
The power is not turned on.	<ul style="list-style-type: none"> • The power has been turned off and on with the I/⏻ key at a short interval. → Wait for about 60 seconds before turning on the power. • The lamp cover is not secured. → Close the lamp cover securely (see page 47). • The air filter cover is detached. → Attach the air filter cover securely (see page 48).

Picture

Symptom	Cause and Remedy
No picture.	<ul style="list-style-type: none"> • A cable is disconnected or the connections are wrong. → Check that the proper connections have been made (see page 23). • The connections are wrong. → This projector is compatible with DDC2B (Digital Data Channel 2B). If your computer is compatible with DDC, turn the projector on according to the following procedures. <ol style="list-style-type: none"> 1 Connect the projector to the computer. 2 Turn the projector on. 3 Start the computer. • Input selection is incorrect. → Select the input source correctly (see page 26). • The picture is muted. → Press the PIC MUTING key to release the picture muting (see pages 16, 18, 20). • The computer signal is not set to output to an external monitor or set to output both to an external monitor and a LCD monitor of a computer. → Set the computer signal to output only to an external monitor (see page 24).
The picture is noisy.	<ul style="list-style-type: none"> • Noise may appear on the background depending on the combination of the number of dots input from the computer and the numbers of pixels on the LCD panel. → Change the desktop pattern on the connected computer. • Input a video signal with the jitter. → Use a TBC (Time Base Corrector) to try to reduce video jitter.
The picture from the INPUT A connector is colored strangely.	<p>The setting of "Input-A Signal Sel." in the Setup menu is incorrect.</p> <p>→ Select "Computer," "Video GBR" or "Component" correctly according to the input signal (see page 43).</p>

Symptom	Cause and Remedy
“Please check Input-A Signal Sel.” appears in spite of inputting the correct signal from INPUT A.	The setting of “Input-A Signal Sel.” in the Setup menu is incorrect. → Select “Computer,” “Video GBR” or “Component” correctly according to the input signal (see page 43).
On-screen display does not appear.	“Status” in the Setup menu has been set to “Off.” → Set “Status” in the Setup menu to “On” (see page 43).
Color balance is incorrect.	<ul style="list-style-type: none"> • The picture has not been adjusted properly. → Adjust the picture (see page 36). • The projector is set to the wrong color system. → Set “Color System” in the Setup menu to match the color system being input (see page 43).
The picture is too dark.	<ul style="list-style-type: none"> • Contrast or brightness has not been adjusted properly. → Adjust the contrast or brightness in the Picture menu properly (see page 36). • The lamp has burnt out or is dim. → Replace the lamp with a new one (see page 46).
The picture is not clear.	<ul style="list-style-type: none"> • The picture is out of focus. → Adjust the focus (see page 28). • Condensation has accumulated on the lens. → Leave the projector for about two hours with the power on.
The image extends beyond the screen.	The APA key has been pressed even though there are black edges around the image. → Display the full image on the screen and press the APA key. → Adjust “Shift” in the Signal menu properly (see page 37).
The picture flickers.	“Dot Phase” in the Signal menu has not been adjusted properly. → Adjust “Dot Phase” in the Signal menu properly (see page 37).

Sound

Symptom	Cause and Remedy
No sound.	<ul style="list-style-type: none"> • A cable is disconnected or the connections are wrong. → Check that the proper connections have been made (see page 23). • The audio connecting cable used is incorrect. → Use a no-resistance stereo audio cable (see page 23). • The sound is muted. → Press the AUDIO MUTING key (VPL-CX100/CX120/CX150 or MUTING (AUDIO) key (VPL-CX125/CX155/CW125) to release audio muting (see pages 18, 20). • The sound is not adjusted properly. → Adjust the sound with the VOLUME +/- key on the Remote Commander. • “Spakaer” in the Function menu is set to “Off.” → Set the “Spakaer” in the Function menu to “On” (see page 39).

Remote Commander

Symptom	Cause and Remedy
The Remote Commander does not work.	<ul style="list-style-type: none"> • The Remote Commander batteries are dead. → Replace them with new batteries (see pages 19, 20). • The COMMAND ON/OFF switch is set to OFF. (VPL-CX125/CX155/CW125 only) → Set it to ON. (page 18) • The ID number of the projector assigned in “ID Mode” in the Installation menu does not match the ID number of the ID MODE keys on the Remote Commander. (VPL-CX125/CX155/CW125 only) → Assigns the same ID number to the projector and the Remote Commander, or set “ID Mode” in the Installation menu to “All” (see pages 18, 42).

Others

Symptom	Cause and Remedy
The control panel keys do not function.	The control panel keys are locked. → Unlock the control panel keys (see page 40).
The fan is noisy.	<ul style="list-style-type: none"> → Check the setting of “High Altitude Mode” in the Installation menu (see page 42). → Check the ventilation holes are not blocked. → Make sure the room temperature is not too high. To maintain the product reliability of the projector’s components, the rotation speed of the fan increases and the fan becomes slightly noisier, when the room temperature exceeds normal. The approximate normal temperature is 25°C.

Indicators

Symptom	Cause and Remedy
The LAMP/COVER indicator flashes in orange. (Repetition rate of 2 flashes)	<ul style="list-style-type: none"> • The lamp cover or the air filter cover is detached. → Attach the cover securely (see pages 46 and 48).
The LAMP/COVER indicator flashes in orange. (Repetition rate of 3 flashes)	<ul style="list-style-type: none"> • The lamp has reached the end of its life. → Replace the lamp (see page 46). • The lamp has reached a high temperature. → Wait for 60 seconds to cool the lamp and then turn on the power again.
ON/STANDBY flashes in red. (Repetition rate of 2 flashes)	<ul style="list-style-type: none"> • The internal temperature is unusually high. → Check to see that nothing is blocking the ventilation holes. • The projector is being used at a high altitude. → Ensure that “High Altitude Mode” in the Installation menu is set to “On.” (see page 42)
ON/STANDBY flashes in red. (Repetition rate of 4 flashes)	The fan is broken. → Consult with qualified Sony personnel.

Symptom	Cause and Remedy
ON/STANDBY flashes in red. (Repetition rate of 6 flashes)	Unplug the AC power cord from the wall outlet after the ON/STANDBY indicator goes out, plug the power cord to the wall outlet, and then turn the projector on again. If the ON/STANDBY flashes in red and the problem persists, the electrical system has failed. → Consult with qualified Sony personnel.

Messages List

Warning Messages

Use the list below to check the meaning of the messages displayed on the screen.

Message	Meaning and Remedy
High temp.! Lamp off in 1 min.	The internal temperature is too high. → Turn off the power. → Check to see that nothing is blocking the ventilation holes.
Frequency is out of range!	<ul style="list-style-type: none"> • This input signal cannot be projected as the frequency is out of the acceptable range of the projector. • The resolution setting of the output signal of the computer is too high. → Input a signal that is within the range of the frequency.
Please check Input-A Signal Sel.	You have input an RGB signal from the computer when “Input-A Signal Sel.” in the Setup menu is set to “Component.” → Set “Input-A Signal Sel.” correctly (see page 43).
Please replace the Lamp and clean the Filter.	<ul style="list-style-type: none"> • It is time to replace the lamp and clean the air filter. → Replace the lamp (see page 46) and clean the filter (see page 48). • If this message appears again after you replace the lamp, the lamp replacement process is not complete. → Perform the operations in step 9 to 12 on page 47. <p>Note To erase a message, press any key on the control panel of the projector or on the remote commander.</p>
High temp.! Probably use in high altitude. Switch to high altitude mode on? Yes ↑ No ↓	Internal temperature is too high. → When using the projector at an altitude of 1,500 m or higher, set “High Altitude Mode” on the Installation menu to “On” (see page 42). → If this message appears on the screen when using the projector at normal altitudes, check to see if anything is blocking the ventilation holes (exhaust) (see page 14).

Caution Messages

Use the list below to check the meaning of the messages displayed on the screen.

Message	Meaning and Remedy
Not applicable!	You have pressed the wrong key. → Press the appropriate key.
The panel keys are locked!	“Panel Key Lock” in the Function menu is set to “On.” → All the keys on the control panel of the projector are locked. Operate the projector with the keys on the Remote Commander (see page 40).

Specifications

Optical characteristics

Projection system	3 LCD panels, 1 lens, 3 primary color shutter system
LCD panel	VPL-CX100/CX120/CX125/ CX150/CX155: 0.79-inch XGA panel, 2,359,296 pixels (1024 × 768 × 3) VPL-CW125: 0.74-inch WXGA panel, 3,280,000 pixels (1366 × 800 × 3)
Lens	1.2 times zoom lens f 23.5 to 28.2 mm/F1.75 to 2.17
Lamp	200 W Ultra high pressure lamp
Projected picture size	40 to 300-inches (measured diagonally)
Light output	VPL-CX150/CX155: 3500 lm VPL-CX120/CX125/CW125: 3000 lm VPL-CX100: 2700 lm (When the Lamp Mode is set to "High.")
Throwing distance (When placed on the floor.)	VPL-CX100/CX120/CX125/ CX150/CX155: (When an XGA signal is input) 40-inch: 1.2 to 1.4 m (3.9 to 4.6 feet) 60-inch: 1.8 to 2.1 m (5.9 to 6.9 feet) 80-inch: 2.4 to 2.8 m (7.9 to 9.2 feet) 100-inch: 3.0 to 3.5 m (9.8 to 11.5 feet) 120-inch: 3.6 to 4.1 m (11.8 to 13.5 feet) 150-inch: 4.5 to 5.2 m (14.8 to 17.1 feet) 180-inch: 5.4 to 6.2 m (17.7 to 20.3 feet) 200-inch: 6.0 to 6.9 m (19.7 to 22.6 feet) 250-inch: 7.5 to 8.7 m (24.6 to 28.5 feet) 300-inch: 9.1 to 10.4 m (29.9 to 34.1 feet) VPL-CW125: (When "Aspect" on the Signal menu is set to "Full 2") 40-inch: 1.3 to 1.5 m (4.3 to 4.9 feet) 60-inch: 1.9 to 2.2 m (6.2 to 7.2 feet)

80-inch:	2.6 to 3.0 m (8.5 to 9.8 feet)
100-inch:	3.2 to 3.7 m (10.5 to 12.1 feet)
120-inch:	3.9 to 4.5 m (12.8 to 14.8 feet)
150-inch:	4.9 to 5.6 m (16.1 to 18.4 feet)
180-inch:	5.9 to 6.7 m (19.4 to 22.0 feet)
200-inch:	6.5 to 7.5 m (21.3 to 24.6 feet)
250-inch:	8.1 to 9.4 m (26.6 to 30.8 feet)
300-inch:	9.8 to 11.3 m (32.2 to 37.1 feet)

There may be a slight difference between the actual value and the design value shown above.

Electrical characteristics

Color system	NTSC3.58/PAL/SECAM/ NTSC4.43/PAL-M/PAL-N/ PAL60 system, switched automatically/manually (NTSC4.43 is the color system used when playing back a video recorded in NTSC on a NTSC4.43 system VCR.)
Resolution	VPL-CX100/CX120/CX125/ CX150/CX155: 750 horizontal TV lines (Video input) 1,024 × 768 dots (RGB input) VPL-CW125: 750 horizontal TV lines (Video input), 1,366 × 800 dots (RGB input)
Acceptable computer signals ¹⁾	fH: 19 to 92 kHz fV: 48 to 92 Hz (Maximum input signal resolution: SXGA+ 1400 × 1050 fV: 60 Hz)
¹⁾ Set the resolution and the frequency of the signal of the connected computer within the range of acceptable preset signals of the projector.	
Applicable video signals	15 k RGB, 50/60 Hz Component, 50/60 Hz Progressive component, DTV (480/60i, 575/50i, 480/60p, 575/50p, 720/60p, 720/50p, 1080/60i, 1080/50i), Composite video, Y/C video
Speaker	Monaural speaker system, 40 × 20 mm (1 ⁵ / ₈ × 2 ⁷ / ₈ inches)
Speaker output	Maximum 1 W × 1

Input/Output

Video input	VIDEO: phono type Composite video: 1 Vp-p \pm 2 dB sync negative (75 ohms terminated) S VIDEO: Y/C mini DIN 4-pin type Y (luminance): 1 Vp-p \pm 2 dB sync negative (75 ohms terminated) C (chrominance): burst 0.286 Vp-p \pm 2 dB (NTSC) (75 ohms terminated), burst 0.3 Vp-p \pm 2 dB (PAL) (75 ohms terminated) AUDIO: stereo minijack 500 mVrms, impedance more than 47 kilohms
INPUT A	HD D-sub15-pin (female) Analog RGB/component: R/R-Y: 0.7 Vp-p \pm 2 dB (75 ohms terminated) G: 0.7 Vp-p \pm 2 dB (75 ohms terminated) G with sync/Y: 1 Vp-p \pm 2 dB sync negative (75 ohms terminated) B/B-Y: 0.7 Vp-p \pm 2 dB (75 ohms terminated) HD:Horizontal sync input: TTL level, high impedance, positive/ negative VD:Vertical sync input: TTL level, high impedance, positive/ negative AUDIO: Stereo minijack rated input 500 mVrms, input impedance more than 47 kilohms
INPUT B	Analog RGB: HD D-sub 15-pin (female) R: 0.7 Vp-p \pm 2 dB (75 ohms terminated) G: 0.7 Vp-p \pm 2 dB (75 ohms terminated) B: 0.7 Vp-p \pm 2 dB (75 ohms terminated) HD: Horizontal sync input: TTL level high impedance, positive/ negative VD: Vertical sync input: TTL level high impedance, positive/ negative AUDIO: Stereo minijack, rated input 500 mVrms, input impedance more than 47 kilohms

INPUT C	NETWORK (VPL-CX125/ CX155/CW125 only) RJ-45: 10BASE-T/100BASE- TX
OUTPUT	MONITOR OUT*: HD D-sub 15- pin (female) R, G, B: Gain Unity: 75 ohms SYNC/HD, VD: 4 Vp-p (open), 1 Vp-p (75 ohms) AUDIO OUT (variable out): Stereo minijack 1 Vrms (When the volume is maximum and an input signal is 500 mVrms), output impedance 5 kilohms
REMOTE	RS-232C: D-sub 9 pin

General

Dimensions	372 \times 90 \times 298 mm (14 ³ / ₄ \times 3 ⁵ / ₈ \times 11 ³ / ₄ inches) (w/h/d) (without the projection parts)
Mass	Approx. 4.1 kg (9 lb 1 oz)
Power requirements	VPL-CX100/CX120/CX125/ CX150/CX155: 100 to 240 V AC, 2.9 - 1.2 A, 50/60 Hz VPL-CW125: 100 to 240V AC, 2.9-1.3A, 50/60 Hz
Power consumption	VPL-CX100/CX120/CX125/ CX150/CX155: Max. 285 W in standby (standard): 7 W in standby (low): 0.5 W VPL-CW125: Max. 287 W in standby (standard): 7 W in standby (low): 0.5 W
Heat dissipation	VPL-CX100/CX120/CX125/ CX150/CX155: 973 BTU VPL-CW125: 979 BTU
Operating temperature	0°C to 35°C (32°F to 95°F)
Operating humidity	35% to 85% (no condensation)
Storage temperature	-20°C to +60°C (-4°F to +140°F)
Storage humidity	10% to 90%
Supplied accessories	Remote Commander (1) Size AA (R6) batteries (2) (VPL- CX125/CX155/CW125) Lithium battery CR2025 (1) (VPL- CX100/CX120/CX150) Lens cap (1) HD D-sub 15 pin cable (2 m) (1) (1-791-992-xx)

- AC power cord (1)
- CD-ROM (Operating Instructions, Application Software) (1)
- Quick Reference Manual (1)
- Safety Regulations (1)
- Security Label (1)

Design and specifications are subject to change without notice.

Note

Always verify that the unit is operating properly before use. SONY WILL NOT BE LIABLE FOR DAMAGES OF ANY KIND INCLUDING, BUT NOT LIMITED TO, COMPENSATION OR REIMBURSEMENT ON ACCOUNT OF THE LOSS OF PRESENT OR PROSPECTIVE PROFITS DUE TO FAILURE OF THIS UNIT, EITHER DURING THE WARRANTY PERIOD OR AFTER EXPIRATION OF THE WARRANTY, OR FOR ANY OTHER REASON WHATSOEVER.

Optional accessories

- Projector Lamp
LMP-C200 (for replacement)
- Presentation Tool
RM-PJPK1

Pin assignment

INPUT A connector (HD D-sub 15-pin, female)

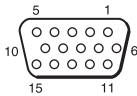

1	R/R-Y	9	Power supply input for DDC
2	G/Y	10	GND
3	B/B-Y	11	GND
4	GND	12	DDC/SDA
5	RESERVE	13	HD
6	GND (R)	14	VD
7	GND (G)	15	DDC/SCL
8	GND (B)		

INPUT B connector (HD D-sub 15-pin, female)

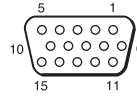

1	R	9	Power supply input for DDC
2	G	10	GND
3	B	11	GND
4	GND	12	DDC/SDA
5	RESERVE	13	HD
6	GND (R)	14	VD
7	GND (G)	15	DDC/SCL
8	GND (B)		

RS-232C connector (D-sub 9 pin, female)

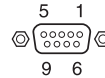

1	NC	6	NC
2	RXDA	7	RTS
3	TXDA	8	CTS
4	DTR	9	NC
5	GND		

Preset signals

Memory No.	Preset signal		fH (kHz)	fV (Hz)	Sync	SIZE
1	Video 60 Hz	Video 60 Hz	15.734	59.940	–	–
2	Video 50 Hz	Video 50 Hz	15.625	50.000	–	–
3	480/60i	DTV 480/60i	15.734	59.940	S on G/Y	–
4	575/50i	DTV 575/50i	15.625	50.000	S on G/Y	–
5	480/60p	480/60p (NTSC Progressive component)	31.470	60.000	S on G/Y	–
6	575/50p	575/50p (PAL Progressive component)	31.250	50.000	S on G/Y	–
7	1080/60i	1035/60i, 1080/60i	33.750	60.000	S on G/Y	–
8	1080/50i	1080/50i	28.130	50.000	S on G/Y	–
10	720/60p	720/60p	45.000	60.000	S on G/Y	–
11	720/50p	720/50p	37.500	50.000	S on G/Y	–
21	640 × 350	VGA mode 1	31.469	70.086	H-pos, V-neg	800
22		VESA 85 (VGA350)	37.861	85.080	H-pos, V-neg	832
23	640 × 400	NEC PC98	24.823	56.416	H-neg, V-neg	848
24		VGA mode 2	31.469	70.086	H-neg, V-pos	800
25		VESA 85 (VGA400)	37.861	85.080	H-neg, V-pos	832
26	640 × 480	VGA mode 3	31.469	59.940	H-neg, V-neg	800
27		Mac 13	35.000	66.667	H-neg, V-neg	864
28		VESA 72	37.861	72.809	H-neg, V-neg	832
29		VESA 75 (IBM M3)	37.500	75.000	H-neg V-neg	840
30		VESA 85	43.269	85.008	H-neg V-neg	832
31	800 × 600	VESA 56	35.156	56.250	H-pos, V-pos	1024
32		VESA 60	37.879	60.317	H-pos, V-pos	1056
33		VESA 72	48.077	72.188	H-pos, V-pos	1040
34		VESA 75 (IBM M5)	46.875	75.000	H-pos, V-pos	1056
35		VESA 85	53.674	85.061	H-pos, V-pos	1048
36	832 × 624	Mac 16	49.724	74.550	H-neg, V-neg	1152
37	1024 × 768	VESA 60	48.363	60.004	H-neg V-neg	1344
38		VESA 70	56.476	70.069	H-neg V-neg	1328
39		VESA 75	60.023	75.029	H-pos, V-pos	1312
40		VESA 85	68.677	84.997	H-pos, V-pos	1376

Others

Memory No.	Preset signal		fH (kHz)	fV (Hz)	Sync	SIZE
41	1152 × 864	VESA 70	63.995	70.019	H-pos, V-pos	1472
42		VESA 75	67.500	75.000	H-pos, V-pos	1600
43		VESA 85	77.487	85.057	H-pos, V-pos	1568
44	1152 × 900	SUN LO	61.795	65.960	H-neg, V-neg	1504
45	1280 × 960	VESA 60	60.000	60.000	H-pos, V-pos	1800
46		VESA 75	75.000	75.000	H-pos, V-pos	1728
47	1280 × 1024	VESA 60	63.974	60.013	H-pos, V-pos	1688
48		SXGA VESA75	79.976	75.025	H-pos, V-pos	1688
49		SXGA VESA85	91.146	85.024	H-pos, V-pos	1728
50	1400 × 1050	SXGA+	65.317	59.978	H-neg, V-pos	1864
55	1280 × 768	1280 × 768/60	47.776	59.870	H-neg, V-pos	1664
56	1280 × 720	1280 × 720/60	44.772	59.855	H-neg, V-pos	1664
60	1360 × 768	1360 × 768/60	44.720	59.799	H-neg, V-pos	1776
63 ^{*1}	1280 × 800	1280 × 800/60	49.702	59.810	H-neg, V-pos	1680

*1: VPL-CW125 only

Preset memory No. at the input signal

Analog signals

Signal	Preset memory No.
Video (Video, S video connector)	1, 2
Component (Input A connector)	3-11
Video GBR (Input A connector)	3-11
Computer (Input A, Input B connector)	21-50, 55, 56, 60, 63 ^{*1}

*1: VPL-CW125 only

Note

When a signal other than the preset signals shown above is input, the picture may not be displayed properly.

Installation Diagram

Floor Installation (Front Projection)

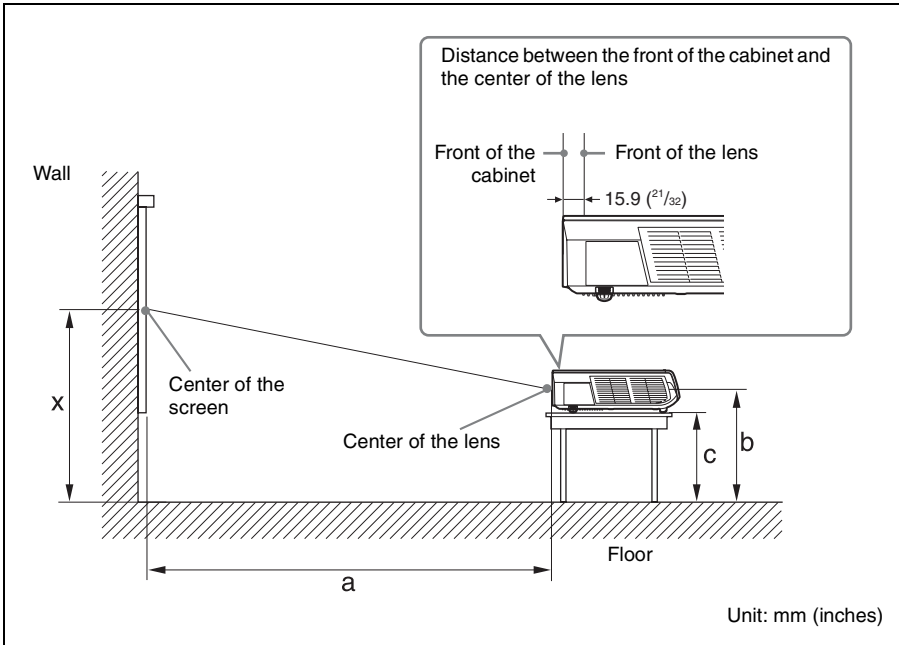

This section describes the examples of installing the projector on a desk, etc.

See the chart on page 60 concerning the installation measurements.

The alphabetical letters in the illustration indicate the distances below.

- a:** distance between the screen and the center of the lens
- b:** distance between the floor and the center of the lens
- c:** distance between the floor and the bottom of the adjusters of the projector
- x:** distance between the floor and the center of the screen (free)

Others

VPL-CX100/CX120/CX125/CX150/CX155

(When an XGA signal is input)

Unit: mm (inches)

PS		40	60	80	100	120	150	180	200	250	300
a	N	1170 (46 1/8)	1770 (69 3/4)	2380 (93 3/4)	2990 (117 3/4)	3590 (141 3/8)	4500 (177 1/4)	5410 (213 1/8)	6020 (237 1/16)	7540 (297)	9050 (356 3/8)
	M	1350 (53 1/4)	2050 (80 3/4)	2750 (108 3/8)	3450 (135 7/8)	4140 (163 1/8)	5190 (204 3/8)	6240 (245 3/4)	6940 (273 3/8)	8680 (341 7/8)	10430 (410 3/4)
b		x-237 (x-9 3/8)	x-356 (x-14)	x-474 (x-18 3/4)	x-593 (x-23 3/8)	x-711 (x-28)	x-889 (x-35)	x-1067 (x-42)	x-1185 (x-46 3/4)	x-1482 (x-58 3/8)	x-1778 (x-70 1/8)
c		x-298 (x-11 3/4)	x-417 (x-16 1/2)	x-535 (x-21 1/8)	x-654 (x-25 3/4)	x-772 (x-30 1/2)	x-950 (x-37 1/2)	x-1128 (x-44 1/2)	x-1247 (x-49 1/8)	x-1543 (x-60 3/4)	x-1839 (x-72 1/2)

$$a (N) = \{(PS \times 23.306/0.7874) - 46.6\} \times 1.025$$

$$a (M) = \{(PS \times 28.188/0.7874) - 45.9\} \times 0.975$$

$$b = x - (PS/0.7874 \times 4.667)$$

$$c = x - (PS/0.7874 \times 4.667 + 61.2)$$

VPL-CW125

(When “Aspect” on the Signal menu is set to “Full 2”)

Unit: mm (inches)

PS		40	60	80	100	120	150	180	200	250	300
a	N	1260 (49 5/8)	1920 (75 5/8)	2570 (101 1/4)	3230 (127 1/4)	3880 (152 7/8)	4870 (191 7/8)	5850 (230 3/8)	6500 (256)	8140 (320 3/8)	9780 (385 7/8)
	M	1460 (57 1/2)	2220 (87 1/2)	2970 (117)	3720 (146 1/2)	4480 (176 1/2)	5610 (211)	6740 (265 1/2)	7490 (295)	9370 (369)	11260 (443 3/8)
b		x-257 (x-10 1/8)	x-385 (x-15 1/4)	x-513 (x-20 1/4)	x-642 (x-25 3/8)	x-770 (x-30 3/8)	x-963 (x-38 29/32)	x-1155 (x-45 1/2)	x-1284 (x-50 5/8)	x-1605 (x-63 3/16)	x-1925 (x-75 7/8)
c		x-318 (x-12 5/8)	x-446 (x-17 5/8)	x-575 (x-22 5/8)	x-703 (x-27 3/4)	x-831 (x-32 3/4)	x-1024 (x-40 3/8)	x-1216 (x-47 7/8)	x-1345 (x-53)	x-1666 (x-65 3/8)	x-1987 (x-78 1/4)

$$a (N) = \{(PS \times 23.3/0.7292) - 46.6\} \times 1.025$$

$$a (M) = \{(PS \times 28.171/0.7292) - 45.650\} \times 0.975$$

$$b = x - (PS/0.7292 \times 4.68)$$

$$c = x - (PS/0.7292 \times 4.68 + 61.2)$$

Notes for VPL-CW125 only

- The projected image size is the one when “Aspect” on the Signal menu is set to “Full 2”. When “Aspect” on the Signal menu is set to other than “Full 2”, black bands appear at the top and bottom or right and left of the screen.
- When “Aspect” in the Signal menu is set to “4:3”, the projected image size (diagonal) will be approximately 84 % of “Full 2” size.
- When “Aspect” in the Signal menu is set to “16:9”, the projected image size (diagonal) will be approximately 99 % of “Full 2” size.

The alphabetical letters in the charts and calculation methods indicate the following.

PS: projected image size measured diagonally (inches)

a: distance between the screen and the center of the lens

b: distance between the floor and the center of the lens

c: distance between the floor and the adjusters of the projector

x: free

N: minimum

M: maximum

Ceiling Installation (Front Projection)

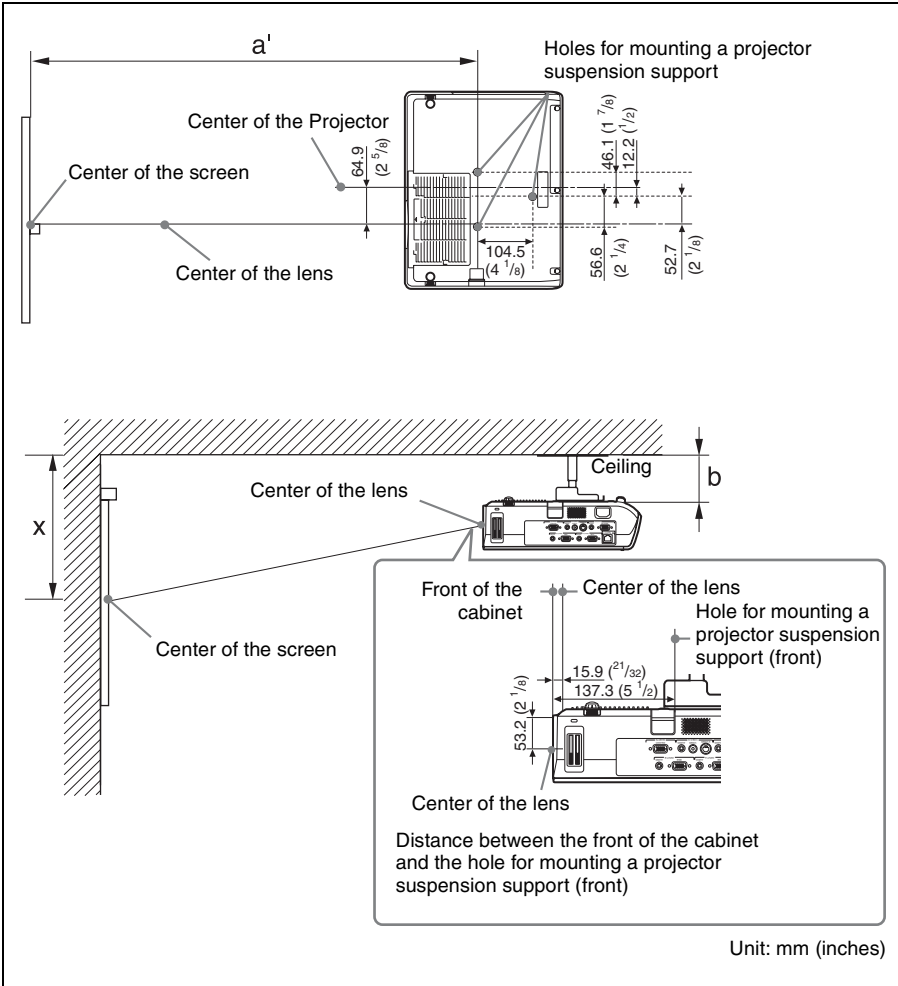

This section describes the examples for installing the projector on the ceiling. When installing the projector on the ceiling, use a Projector Suspension Support recommended by Sony.

For ceiling installation, ask for qualified Sony personnel.

See the chart on page 62 concerning the installation measurements.

The alphabetical letters in the illustrations indicate the distances below.

- a'**: distance between the hole(front) for mounting a projector suspension support on bottom surface of this projector and the center of the screen
- b**: distance between the projector suspension support mounting surface on bottom of this projector and the ceiling
- x**: distance between the ceiling and the center of the screen

Others

VPL-CX100/CX120/CX125/CX150/CX155

(When an XGA signal is input)

Unit: mm (inches)

PS	40	60	80	100	120	150	180	200	250	300	
a'	N	1290 (50 ²⁵ / ₃₂)	1900 (74 ⁷ / ₈)	2500 (98 ¹ / ₂)	3110 (122 ¹ / ₂)	3720 (146 ¹ / ₂)	4630 (182 ³ / ₈)	5540 (218 ¹ / ₄)	6140 (241 ⁷ / ₈)	7660 (301 ⁵ / ₈)	9180 (361 ¹ / ₂)
	M	1470 (57 ⁷ / ₈)	2170 (85 ¹ / ₂)	2870 (113 ¹ / ₈)	3560 (140 ¹ / ₄)	4260 (167 ³ / ₄)	5310 (209 ¹ / ₈)	6360 (250 ¹ / ₂)	7050 (277 ⁵ / ₈)	8800 (346 ¹ / ₂)	10540 (415 ¹ / ₈)
x	b+290 (b+11 ¹ / ₂)	b+409 (b+16 ¹ / ₈)	b+527 (b+20 ³ / ₄)	b+646 (b+25 ¹ / ₂)	b+764 (b+30 ¹ / ₈)	b+942 (b+37 ¹ / ₈)	b+1120 (b+44 ¹ / ₈)	b+1239 (b+48 ⁷ / ₈)	b+1535 (b+60 ¹ / ₂)	b+1831 (b+72 ¹ / ₈)	
b	Free										

$$a'(N) = \{(PS \times 23.306/0.7874) + 74.757\} \times 1.025$$

$$a'(M) = \{(PS \times 28.188/0.7874) + 75.509\} \times 0.975$$

$$x = b + (PS/0.7874 \times 4.667 + 53.2)$$

VPL-CW125

(When “Aspect” on the Signal menu is set to “Full 2”)

Unit: mm (inches)

PS	40	60	80	100	120	150	180	200	250	300	
a	N	1390 (54 ³ / ₄)	2040 (80 ³ / ₈)	2700 (106 ³ / ₈)	3350 (132)	4010 (157 ²⁹ / ₃₂)	4990 (196 ¹ / ₂)	5970 (235 ³ / ₈)	6630 (261 ¹ / ₈)	8260 (325 ¹ / ₄)	9900 (389 ⁷ / ₈)
	M	1580 (62 ¹ / ₄)	2330 (91 ³ / ₄)	3090 (121 ³ / ₄)	3840 (151 ¹ / ₄)	4590 (180 ³ / ₄)	5720 (225 ¹ / ₄)	6850 (269 ³ / ₄)	7610 (299 ³ / ₄)	9490 (373 ³ / ₄)	11370 (447 ³ / ₄)
x	b+310 (b+12 ¹ / ₄)	b+438 (b+17 ¹ / ₄)	b+567 (b+22 ³ / ₈)	b+695 (b+27 ³ / ₈)	b+823 (b+32 ¹ / ₂)	b+1016 (b+40)	b+1208 (b+47 ³ / ₈)	b+1337 (b+52 ³ / ₄)	b+1658 (b+65 ³ / ₈)	b+1979 (b+78)	
b	Free										

$$a'(N) = \{(PS \times 23.3/0.7292) + 75.145\} \times 1.025$$

$$a'(M) = \{(PS \times 28.171/0.7292) + 75.75\} \times 0.975$$

$$x = b + (PS/0.7292 \times 4.68 + 53.2)$$

Notes for VPL-CW125 only

- The projected image size is the one when “Aspect” on the Signal menu is set to “Full 2”. When “Aspect” on the Signal menu is set to other than “Full 2”, black bands appear at the top and bottom or right and left of the screen.
- When “Aspect” in the Signal menu is set to “4:3”, the projected image size (diagonal) will be approximately 84 % of “Full 2” size.
- When “Aspect” in the Signal menu is set to “16:9”, the projected image size (diagonal) will be approximately 99 % of “Full 2” size.

The alphabetical letters in the charts and calculation methods indicate the following.

PS: projected image size measured diagonally (inches)

a': distance between the hole (front) for mounting a projector suspension support on bottom surface of this projector and the center of the screen

b: distance between the projector suspension support mounting surface on bottom of this projector and the ceiling

x: distance between the center of the screen and the ceiling

N: minimum

M: maximum

“Side Shot” (VPL-CX125/CX155/CW125 only) and “V Keystone” Adjustments

With “Side Shot” (horizontal keystone adjustment) provided for the projector, you can project the picture from the side of the screen.

When projecting with “Side Shot” adjustment only, you can adjust the horizontal distortion of the screen to the maximum using “Side Shot.”

When projecting with both “Side Shot” and “V Keystone” (vertical keystone adjustment), you can adjust the vertical (◻ ◻) and horizontal (◻ ◻) distortion of the screen.

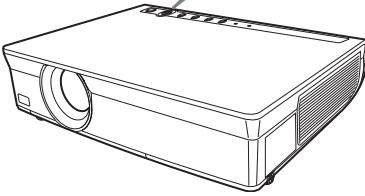
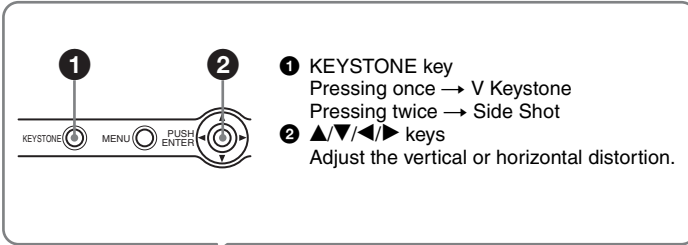

Adjustment Areas of “Side Shot” and “V Keystone”

The adjustable distortion area using “Side Shot” and “V Keystone” is described below.

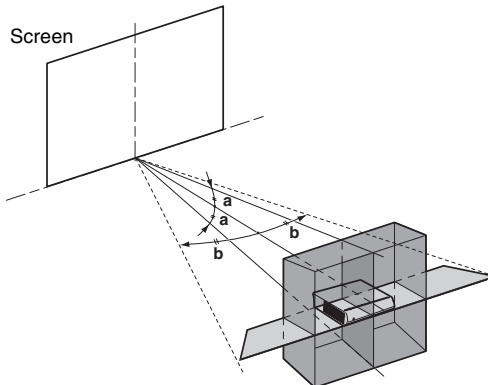

- a:** Tilting angle of the projector in the “V Keystone” adjustment area
- b:** “Side Shot” (H Keystone adjustment) area

Others

VPL-CX125/CX155

Input signals		a	b
Video/60, Video/50, 480/60i, 575/50i, 480/60p, 575/50p	a=0	0	+/-15
	a≠0 or b≠0	+/-18	+/-8
	b=0	+/-25	0
1080/60i, 1080/50i, 540/60p	a=0	0	+/-13
	a≠0 or b≠0	+/-18	+/-8
	b=0	+/-25	0
720/60p, 720/50p	a=0	0	+/-13
	a≠0 or b≠0	+/-18	+/-6
	b=0	+/-25	0
PC (Preset signal No.21 to 49, 51 to 60), Air Shot, except SXGA+	a=0	0	+/-11
	a≠0 or b≠0	+/-18	+/-6
	b=0	+/-25	0
PC (Preset signal No.50), SXGA+	a=0	0	+/-7
	a≠0 or b≠0	+/-18	+/-4
	b=0	+/-25	0

VPL-CW125

Input signals		a	b
Video/60, Video/50, 480/60i, 575/50i, 480/60p, 575/50p	a=0	0	+/-16
	a≠0 or b≠0	+/-19	+/-9
	b=0	+/-22	0
1080/60i, 1080/50i, 540/60p	a=0	0	+/-13
	a≠0 or b≠0	+/-19	+/-9
	b=0	+/-22	0
720/60p, 720/50p	a=0	0	+/-13
	a≠0 or b≠0	+/-19	+/-6
	b=0	+/-22	0
PC (Preset signal No.21 to 40), Air Shot	a=0	0	+/-11
	a≠0 or b≠0	+/-19	+/-6
	b=0	+/-22	0
PC (Preset signal No.41 to 63)	a=0	0	+/-7
	a≠0 or b≠0	+/-19	+/-3
	b=0	+/-22	0

Notes

- If “V Keystone” is set to “Auto,” the “Side Shot” adjustment area may be narrow.
- “V Keystone” on the Installation menu is set to “Auto” at the factory, and the vertical distortion of the picture is automatically corrected. However, the distortion may not be perfectly corrected depending on the room temperature or the screen angle. In this case, set this item to “Manual,” and correct the distortion using input values.

Dimensions

Front

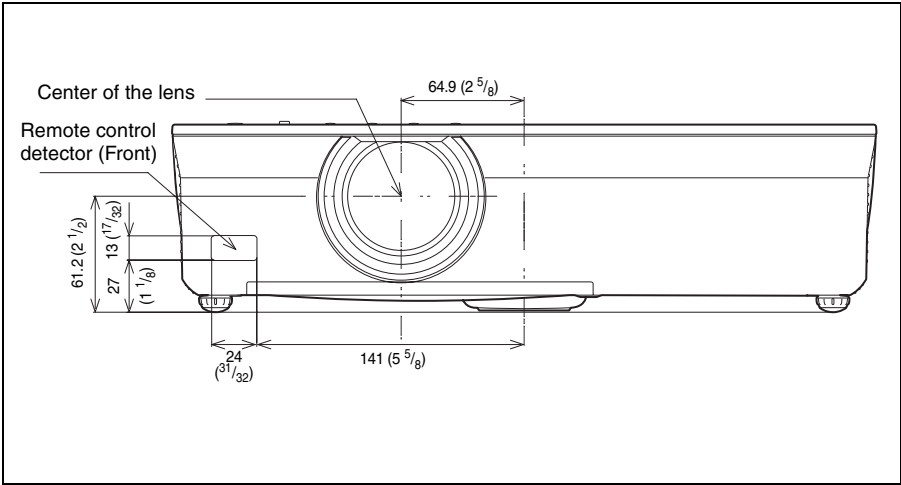

Unit: mm (inches)

Top

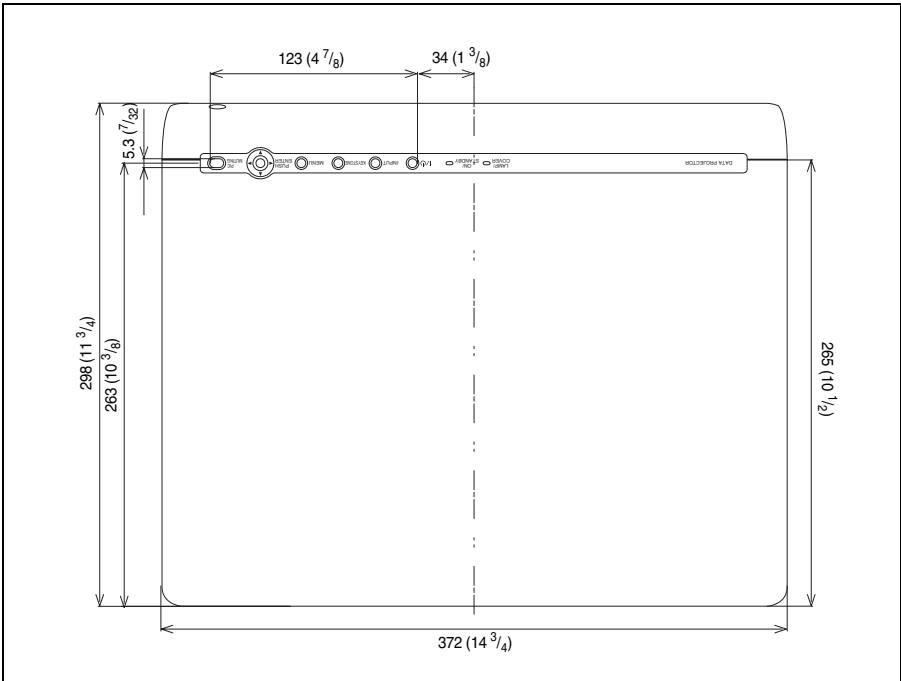

Unit: mm (inches)

Others

Side

Center of the lens

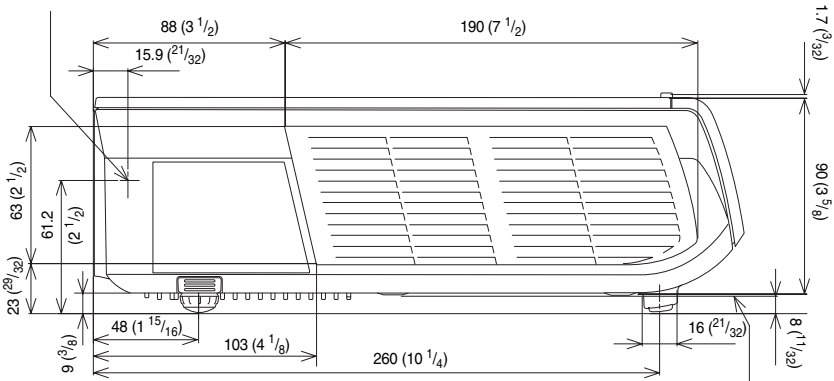

Projector suspension support mounting surface

VPL-CX125/CX155/CW125 only

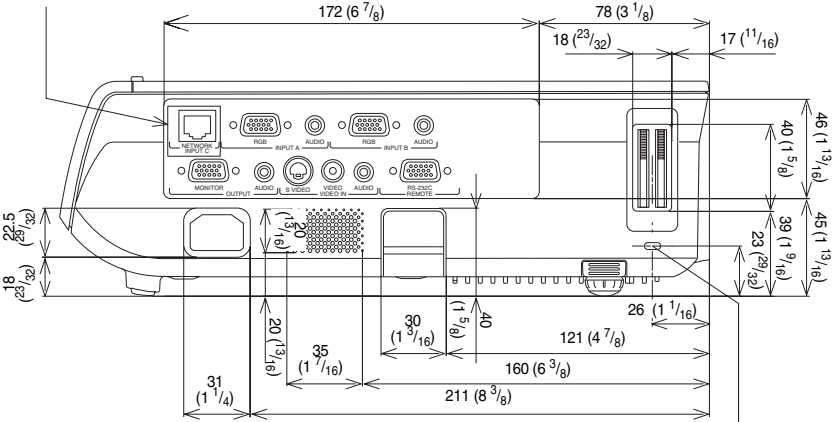

Hole for security lock

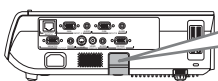
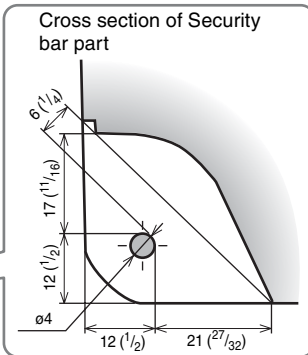

Unit: mm (inches)

Rear

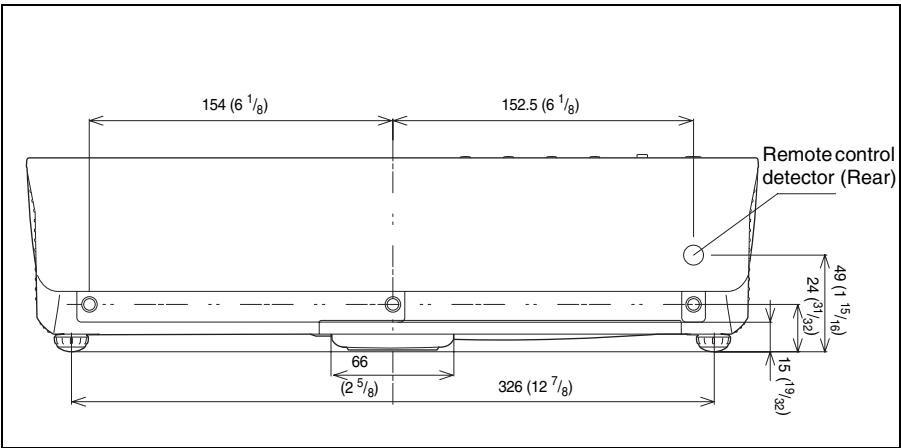

Unit: mm (inches)

Bottom

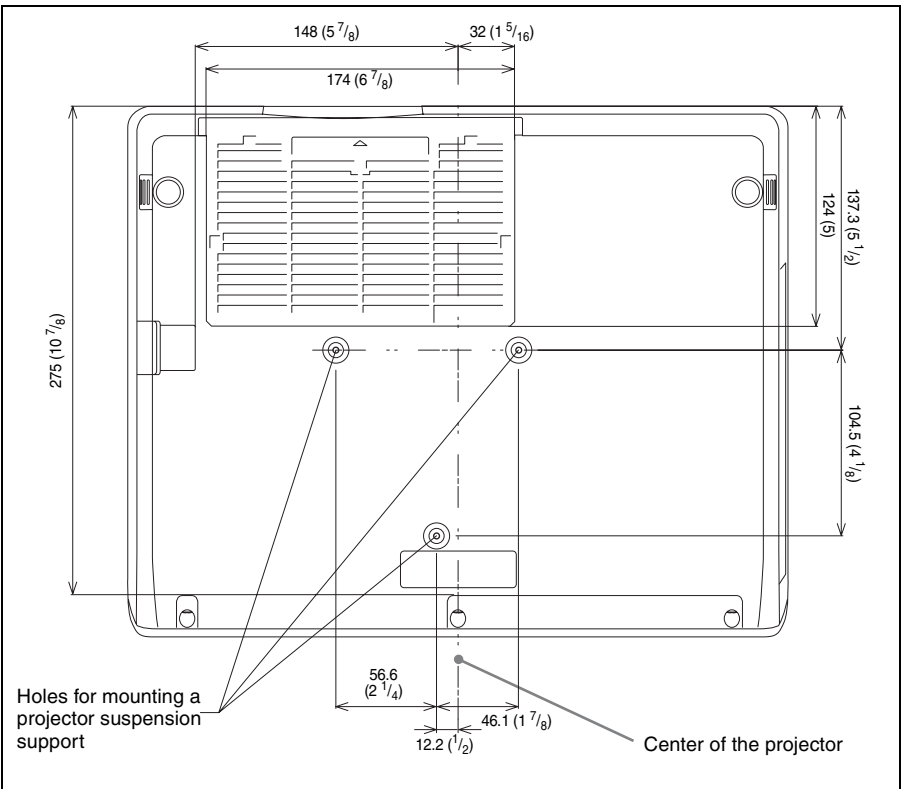

Unit: mm (inches)

Others

Index

A

Adjuster	27
Air filter	48
Aspect	37, 38
Auto Input Search	39

B

Background	41
Brightness	36

C

Cleaning the air filter	48
Color	36
Color System	43
Color Temp.	36
Connecting a computer	23
Connecting a VCR	24
Contrast	36

D

Digital Zoom function	32
Dimensions	65
Direct Power On	42
Direct power On/Off function	32
Dot Phase	37

F

fH (Horizontal Frequency)	44
Freeze function	32
fV (Vertical Frequency)	44

G

Gamma Mode	36
------------------	----

H

H Size	37
High Altitude Mode	42
Hue	36

I

ID Mode	42
Image Flip	41
Input-A Signal Sel.	43
Installation diagram	
Ceiling installation	61

Floor installation	59
Installing the projector	21
IR Receiver	41

L

Lamp Mode	41
Lamp Timer	44
Lamp Timer Reset	43
LAMP/COVER indicators	15
Language	43
Location and function of controls	
Connector panel	16
Control panel	15
Rear/Side/Bottom	13
Top/Front/Side	13

M

Maintenance	46
Memory No.	44
Menu	
Function menu	39
Information menu	44
Installation menu	41
Picture menu	36
Setup menu	43
Signal menu	37
Menu language	29
Messages list	
Caution messages	53
Warning messages	53
Model name	44

O

ON/STANDBY indicator	15
Optional accessories	56

P

Panel Key Lock	40
Picture Mode	36
Pin assignment	56
Power Saving	40
Precautions	6
Preset Memory No.	38, 58
Preset signals	57
Projecting	26

R

Remote Commander	17
Replacing the Lamp	46

S

Screen size	21
Security bar	14, 66
Security Lock	40
Security lock	14
Serial number	44
Sharpness	36
Shift	37
Side Shot	41, 63
Signal type	44
Smart APA	39
Speaker	39
Specifications	54
Standby Mode	39
Start Up Image	39
Status	43
Supplied accessories	55

T

Test Pattern	39
Troubleshooting	49

V

V Keystone	41, 63
Volume	36

