

Replacement Instructions

Lamp unit for LCD Projector

Model No. **ET-LAX100**

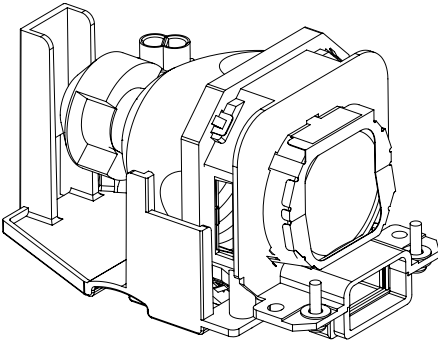

Read these instructions completely before replacement.

Information on Disposal for Users of Waste Electrical & Electronic Equipment (private households)



This symbol on the products and/or accompanying documents means that used electrical and electronic products should not be mixed with general household waste.

For proper treatment, recovery and recycling, please take these products to designated collection points, where they will be accepted on a free of charge basis. Alternatively, in some

countries you may be able to return your products to your local retailer upon the purchase of an equivalent new product.

Disposing of this product correctly will help to save valuable resources and prevent any potential negative effects on human health and the environment which could otherwise arise from inappropriate waste handling. Please contact your local authority for further details of your nearest designated collection point.

Penalties may be applicable for incorrect disposal of this waste, in accordance with national legislation.

For business users in the European Union

If you wish to discard electrical and electronic equipment, please contact your dealer or supplier for further information.

Information on Disposal in other Countries outside the European Union

This symbol is only valid in the European Union.

If you wish to discard this product, please contact your local authorities or dealer and ask for the correct method of disposal.

Precautions with regard to safety

Warning

The lamp unit should only be replaced by a qualified technician.

When replacing the lamp, allow it to cool for at least one hour before handling it.

- The lamp cover gets very hot, and contact with it can cause burns.

Notes on replacing the lamp unit

- The light generating lamp is made of glass, so dropping it or allowing it to hit hard objects may cause it to burst. Be careful when handling the lamp.
- Dispose of the removed the old lamp with the same care that would be taken with a fluorescent light.
- A Phillips screwdriver is necessary for removing the lamp unit.
- Grip the handle when you remove the lamp unit. Some parts of the lamp unit are sharpened and may cause injury.

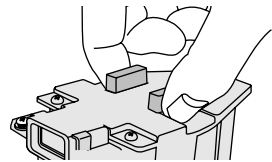

NOTICE:

For USA only

Hg-LAMP CONTAINS MERCURY, Manage in Accord with Disposal Laws,

See: www.lamprecycle.org or 1-888-411-1996

Replacing the lamp unit

NOTE:

- If the lamp usage time has passed 2 000 hours (when LAMP POWER has been set to “NORMAL”), the projector will switch to standby mode after approximately 10 minutes of operation. The steps ⑧ to ⑪ on the following pages should thus be completed within 10 minutes.
- If the LCD projector is operating, turn off the power by the following procedure and wait for the lamp unit to cool down before carrying out replacement.
 - (1) Hold down the POWER button for at least 0.5 seconds or press the POWER button twice to turn off the power.
(The power indicator lamp will illuminate orange.)
 - (2) Wait until the cooling fan stops and the power indicator lamp switches to red.
 - (3) Turn off the MAIN POWER switch and disconnect the power cord plug from the wall outlet.

Lamp unit replacement procedure

- ① Check that the area around the lamp unit has cooled down.
- ② Use a Phillips screwdriver to turn the lamp unit cover fixing screws at the bottom of the projector, and then remove the lamp unit cover from the projector.

Lamp unit cover fixing screws

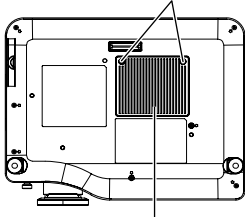

Lamp unit cover

- ③ Use a Phillips screwdriver to loosen the two lamp unit fixing screws until the screws turn freely. Then hold the handle of the lamp unit and gently pull it out from the projector.

Lamp unit fixing screws

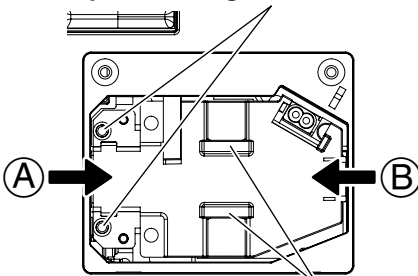

Handle

- ④ Insert the new lamp unit while making sure that the direction of insertion is correct, and then use a Phillips screwdriver to securely tighten the lamp unit fixing screws.

When inserting the new lamp unit, be sure to push it in at the point **A** and **B**.

- ⑤ Install the lamp unit cover, and then use a Phillips screwdriver to securely tighten the lamp unit cover fixing screws.

NOTE:

- Be sure to install the lamp unit and the lamp unit cover securely. If they are not securely installed, it may cause the protection circuit to operate so that the power cannot be turned on.

- ⑥ Insert the power cord plug into the wall outlet and then press the MAIN POWER switch.
- ⑦ Press the POWER button so that a picture is projected onto the screen.
- ⑧ Press the MENU button to display the menu screen, and then press the ▲ or ▼ button to select the “OPTION” menu.

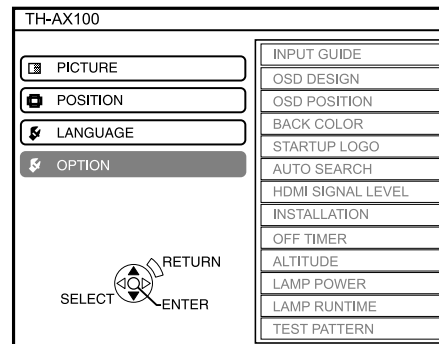

- ⑨ Press the ENTER button, and then press the ▲ or ▼ button to select “LAMP RUNTIME”.

INPUT GUIDE	DETAILED
OSD DESIGN	TYPE1
OSD POSITION	CENTER
BACK COLOR	BLUE
STARTUP LOGO	ON
AUTO SEARCH	ON
HDMI SIGNAL LEVEL	NORMAL
INSTALLATION	FRONT/DESK
OFF TIMER	OFF
ALTITUDE	NORMAL
LAMP POWER	NORMAL
LAMP RUNTIME	1820H
TEST PATTERN	

- ⑩ Press and hold the ENTER button for approximately 3 seconds.

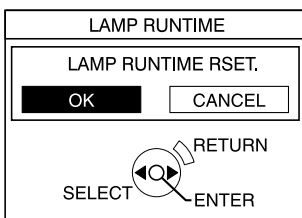

- ⑪ Press the ◀ or ▶ button to select “OK”, and then press the ENTER button.

This will reset the cumulative usage time for the lamp unit to zero.

- ⑫ Replace the air filter with the new filter which is supplied as an accessory, while referring to the replacement procedure which appears in the Operating Instructions for the LCD projector.

Accessory

- Air filter : 1

These Operating Instructions are printed on recycled paper.

Matsushita Electric Industrial Co., Ltd.

Web Site: <http://www.panasonic.co.jp/global/>
<http://www.pureglare.com.au>

Printed in Japan