

User Manual

LED Wall Clock With Calendar and Temperature Display



Specifications:

- Remote Power: 2 x AA Batteries (required)
- Remote Distance: 8m
- Mounting holes: Yes
- Power: 9VDC Power Supply (memory backup with 3 x AAA batteries)
- Dimensions: 314(L) x 164(W) x 40(D) mm

Flyout:

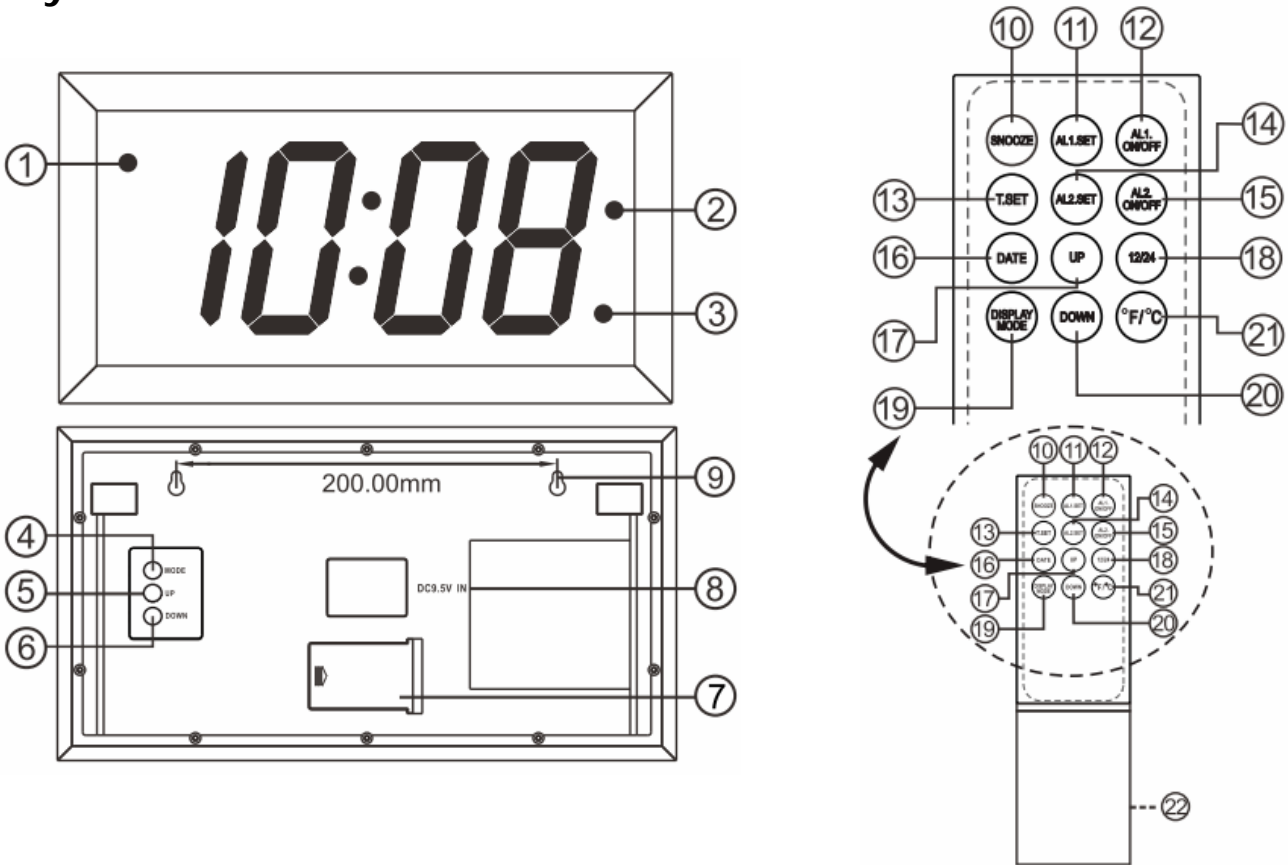

On Clock:

- 1. PM indicator (for 12Hr mode only)
- 2. Alarm 1 ON indicator
- 3. Alarm 2 ON indicator
- 4. Mode button
- 5. Up button
- 6. Down button
- 7. Battery compartment
- 8. DC Adaptor Input Socket
- 9. Mounting Hole

On Remote:

- 10. Snooze button
- 11. Alarm 1 Set
- 12. Alarm 1 ON/OFF
- 13. Time Set
- 14. Alarm 2 Set
- 15. Alarm 2 ON/OFF
- 16. DATE
- 17. UP
- 18. 12/24 hour mode
- 19. Display mode
- 20. Down
- 21. Temp °C/°F
- 22. Battery Compartment

Instructions:

- Please check the mains specification before plugging into the socket.
- Plug the power adaptor into the DC input socket, and then plug the adaptor into the wall socket. The clock digits will flash to indicate it is working properly.

Clock backup:

Insert 3 x AAA batteries into the battery compartment of the clock. This function prevents the clock time from being lost when power has been lost by the unit. The display will not show in this instance but the battery will keep the clock IC running until the power is restored.

Remote control:

Insert 2 x AA batteries into the battery compartment of the remote control.

Using the clock:

Setting alarm 1:

- Press the 'MODE' button to enter the alarm 1 setting mode. The hour digit and the AL1 indicator will flash, and then press the 'UP' or 'DOWN' button to adjust the hour.
- Press the 'MODE' button again to toggle to adjust the minute. The minute digit will flash, and then press the 'UP' or 'DOWN' button to adjust the minute.

Setting alarm 2:

- Follow from above; press the 'MODE' button to enter the alarm 2 setting mode. The hour digit and the AL2 indicator will flash, and then press the 'UP' or 'DOWN' button to adjust the hour.
- Press the 'MODE' button again to toggle to adjust the minute. The minute digit will flash, and then press the 'UP' or 'DOWN' button to adjust the minute.

Setting the hour format (12H or 24H):

- Follow from above; press the 'MODE' button to enter the hour format setting mode. The display will show "12H" or "24H", and then press the 'UP' button to toggle between "12H" for 12 hour format and "24H" for 24 hour format.

Setting the time:

- Follow from above; press the 'MODE' button to enter the TIME setting mode. The hour digit will flash, and then press the 'UP' or 'DOWN' button to adjust the hour.
- Follow from above; press the 'MODE' button to enter the minute setting mode. The minute digit will flash, and then press the 'UP' or 'DOWN' button to adjust the minute.

Setting the year:

- Follow from above; press the 'MODE' button to enter the year setting mode. The year digit will flash, and then press the 'UP' or 'DOWN' button to adjust the year.

Setting the Date Format (D-M or M-D):

- Follow from above; press the 'MODE' button to enter to enter the date format setting mode. The display will flash 'nn dd' or 'dd nn', and then press the 'UP' or 'DOWN' button to adjust the date format.
nn = month, dd = day.

Setting the month/day:

- Follow from above; press the 'MODE' button to enter the month setting mode. The month digit will flash, and then press the 'UP' or 'DOWN' button to adjust the month.
- Follow from above; press the 'MODE' button to enter the day setting mode. The day digit will flash, and then press the 'UP' or 'DOWN' button to adjust the day.

Setting temperature unit (°C/°F):

- Follow from above; press the 'MODE' button to enter the temperature unit setting mode. The display will flash, and then press the 'UP' button to adjust to °C or °F. Once the setting is complete, the display will return to show the time.

Using the remote control:**Setting the time:**

- Press and hold the 'T.SET' button for 2 seconds, to enter the time setting mode. The hour digit will flash, and then press the 'UP' or 'DOWN' button to adjust the hour.
- Follow from above; press the 'T.SET' button to enter the minute setting mode. The minute digit will flash, and then press the 'UP' or 'DOWN' button to adjust the minute.

Setting the hour format (12H or 24H):

- Press and hold the '12/24' button for 2 seconds to enter the hour format setting mode. The display will show "12H" or "24H", and then press the 'UP' button to toggle between "12H" for 12 hour format or "24H" for 24 hour format.

Setting the year:

- Press and hold the 'DATE' button for 2 seconds to enter the year setting mode. The year digit will flash, and then press the 'UP' or 'DOWN' button to adjust the year.

Setting the date format (D-M or M-D):

- Follow from above; press the 'DATE' button to enter the date format setting mode. The display will flash 'nn dd' or 'dd nn', and then press the 'UP' button to adjust the date format. nn = month, dd = day.

Setting the month/day:

- Follow from above; press the 'DATE' button to enter the month setting mode. The month digit will flash, and then press the 'UP' or 'DOWN' button to adjust the month.
- Follow from above; press the 'DATE' button to enter the day setting mode. The day digit will flash, and then press the 'UP' or 'DOWN' button to adjust the display.

Setting the temperature unit (°C or °F):

- Press and hold the °C/°F button for 2 seconds to enter the temperature unit setting mode. The current displayed temperature will flash, and then press the 'UP' button to toggle between °C or °F.

Setting Alarm 1:

- Press and hold the 'AL.1 SET' button for 2 seconds to enter the Alarm 1 setting mode. The hour digit and the AL1 indicator will flash, and then press the 'UP' or 'DOWN' button to adjust the hour.
- Follow from above; press the 'AL.1 SET' button to toggle the minute. The minute digit will flash, and then press the 'UP' or 'DOWN' button to adjust the minute.

Setting Alarm 2:

- Press and hold the 'AL.2 SET' button for 2 seconds to enter the Alarm 2 setting mode. The hour digit and the AL2 indicator will flash, and then press the 'UP' or 'DOWN' button to adjust the hour.
- Follow from above; press the 'AL.2 ST' button to toggle the minute. The minute digit will flash, and then press the 'UP' or 'DOWN' button to adjust the minute.

Activating the alarm:

There are two ways to activate the alarm, either by using the buttons on the back of the clock, or by using the remote handset.

Using the buttons on the clock:

- To turn on Alarm 1, press and hold the 'UP' button for 2 seconds and the AL1 dot on the display will flash to show the alarm time. Press the 'UP' button to toggle the alarm on or off. The AL.1 dot will light up to indicate Alarm 1 is on.
- To turn on Alarm 2, press and hold the 'DOWN' button for 2 seconds and the AL2 dot on the display will flash to show the alarm time. Press the 'DOWN' button to toggle the alarm on or off. The AL.2 dot will light up to indicate Alarm 2 is on.

NOTE: Alarm 1 will beep twice every second, while Alarm 2 will beep 3 times every second.

Stopping the alarm:

When the alarm comes on, the corresponding alarm indicator will flash to indicate that alarm is active. You can stop the alarm either by using the buttons on the back of the clock or by using the remote control. If the alarm comes on and is not manually stopped, it will only sound for 5 minutes before stopping for the rest of the day.

Using the buttons on the clock:

- Press any key on the back of the clock. The alarm will be stopped for the rest of the day.

Using the remote control:

- Press any key on the remote control. The alarm will be stopped for the rest of the day.

Snooze:

- When the alarm comes on, the corresponding alarm indicator will flash to indicate that alarm is active. On the remote control, press the 'SNOOZE' button and the alarm will be turned off for 8-9 minutes before coming back on. You can repeat this cycle repeatedly.

Dimming the brightness:

- In the normal mode, press the 'SNOOZE' button on the remote control to change the display brightness. The brightness will cycle from bright to dim, then from dim to bright.

Changing the display modes:

There are 6 different display modes for the user to select from:

1. **H** shows only the TIME
2. **d** shows only the DATE
3. **7E** shows only the TEMPERATURE
4. **6** shows the TIME for 6 seconds, the DATE for 2 seconds, the TIME for 6 seconds, and then the TEMPERATURE for 2 seconds.
5. **15** shows the TIME for 15 seconds, the DATE for 2 seconds, the TIME for 15 seconds, and the TEMPERATURE for 2 seconds.
6. **30** shows the TIME for 30 seconds, the DATE for 2 seconds, the TIME for 30 seconds, and then the TEMPERATURE for 2 seconds.

NOTE:

- It is advisable to change the clock batteries every 6-9 months for optimal performance. Do not mix new and old batteries, for best results use alkaline batteries.
- If the device is being put into storage, please remove the batteries.
- Do not attempt to open, repair, or modify any part of the clock or the remote control.
- Do not get the clock or the remote control wet in any way.
- For cleaning, using a soft damp cloth that is free of any solvents or detergents as they can damage the LCD.